

On DC-Segmentation of Interconnected Power Systems

Reza Gholizadeh Roshanagh¹

Sajad Najafi Ravadanegh²

¹ PhD Student -Smart Distribution Grid Research Lab, Department of Electrical Engineering, Azarbaijan Shahid Madani University, Tabriz, Iran

² Associate Professor -Smart Distribution Grid Research Lab, Department of Electrical Engineering, Azarbaijan Shahid Madani University, Tabriz, Iran
S.najafi@azaruniv.edu

Abstract:

The ultimate goal of power system operation and planning is to increase power system reliability which enforces interconnected operation of power system. As a result of power system interconnection, the inter-area oscillation under different disturbances may cause power system partial or total blackout. DC-segmentation of interconnected power systems is a solution in which the topology of the network is changed by dividing it into small segments, and connecting them by DC-links. From the dynamic operation and planning aspects of the power system, the controllability of the system at the presence of multiple HVDC links used for segmented power system is a complicated problem. In this paper a procedure to study the concept of power system DC-segmentation using the DC-links as a grid shock absorber is introduced. A well-established evolutionary technique, namely imperialist competitive algorithm (ICA) is used to design a HVDC supplementary controller for a non-segmented interconnected power system. The performance of the controller and the DC-segmented system is investigated after DC-segmentation. The obtained results show the potential value of using supplementary controllers in the DC-segmented power networks.

Keywords: Power System DC-segmentation, HVDC supplementary controller, Imperialist Competitive Algorithm, Optimization, Blackout.

Submission date: 7, Jan., 2013

Conditionally Acceptance date: 10, May, 2014

Acceptance date: 05, Jul., 2014

Corresponding author: Sajad Najafi Ravadanegh

Corresponding author's address: Tabriz-Azarshahr Main Road, Smart Distribution Grid Research Lab, Department of Electrical Engineering, Azarbaijan Shahid Madani University, Tabriz, Iran.



1. Introduction

Inter-area oscillation is one of the topological characteristics of interconnected AC power systems. Uncontrolled inter-area oscillations may lead to power system partial or total blackout. Recently a new concept based on system DC-segmentation is proposed to suppress the effect of the phenomena [1]-[3]. To solve the problem, power system experts suggest that DC-segmentation of large interconnected power systems is an appropriate solution [4]-[9]. The DC-segmentation is based on dividing the system into small segments and connecting them by DC-links. By DC-segmentation of large interconnected power systems, the power transfer capability increases, and market operations are performed in a better way; but the main effect is that the DC-links can act as firewalls against faults and disturbances [4].

The research on the DC-segmentation concept is in its early stage. Discussions on this proposal have been underway from early 1980s [1], and the first systematic work on this solution was published in 2008 [4]. Authors in [1]-[5] considerably tried to introduce the concept, but their work lacked the deep analytical study into DC-segmentation. In [6], control of BtB VSC-HVDC links for DC-segmented systems, was investigated. Authors in [7] presented loss of AC line in a parallel AC-DC transmission system in order to evaluate DC-segmentation concept. Damping of low-frequency oscillations by tuning the operating point of a DC-segmented AC system was presented in [8]. And authors in [9] studied the DC-segmentation concept in terms of its impact on security indices. In addition to above, authors in [3] indicated that CSC-HVDC links could be used in the DC-segmentation, but there is no research on its application and control for such systems.

There have been many installations of CSC-HVDC links throughout the world, which they could pave the way for the upcoming DC-segmentation projects. The controllers designed for the existent CSC-HVDC links could be taken advantage of in the new topology of DC-segmentation. In this paper an HVDC supplementary controller based on a novel evolutionary technique, namely imperialist competitive algorithm [10], is designed for a non-segmented interconnected power system, and considering it as an existent controller, DC-segmented system is investigated.

The rest of the paper is structured as follows: Section 2 describes the control of DC-links in DC-segmented power systems. In section 3, ICA technique is briefly explained. The test-system, used in the simulation, is described in section 4. The designing process of HVDC supplementary controller is presented in section 5, and section 6 discusses the obtained results of ICA implementation as well as time domain simulations. Finally, a brief summary of the paper and concluding remarks are given in section 7.

2. Control in Segmented Power Systems

Control of DC-links in DC-segmented power systems can be of two kinds: in normal condition and under disturbance condition [5]. In normal condition, the DC power is set to a target value depending on the operators' agreement. Under disturbance condition, different methods could be used to respond to the contingency by means of DC-link. The power order of the DC-link can be set by an operator, modulated for damping of electromechanical swings or be automatically re-set by a remedial action scheme (RAS) or special protection scheme (SPS) [11].

HVDC supplementary controller, as a way of modulating the power or current order of a DC-link, is used here in order to study its impact on a DC-segmented system. It should be noted that the methodology to design the controller is well researched but in this paper, ICA, as an evolutionary algorithm is used to tune the controller parameters. The main advantage of the ICA is in its relatively fast convergence. Application of ICA in designing supplementary controllers can be considered as one of the novelties for the paper. In addition, the adaption of an existent supplementary controller in a DC-segmented power system is another novelty of the paper.

3. ICA Technique

Like other evolutionary algorithms, ICA starts with an initial population, which is called country and is divided into two types, colonies and imperialists, which together form empires. Every country could be defined as a vector (Fig. 1) with socio-political characteristics such as culture, language, and religion.

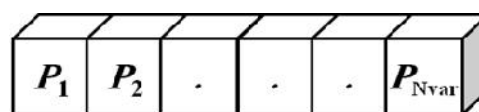

Fig. 1. Representation of a country in ICA, with its variables

The primary locations of each country is determined by the set of values assigned to each decision variable randomly as

$$D_i(0) = D_{i,\min} + \text{rand}(D_{i,\max} - D_{i,\min}) \quad (1)$$

Where $D_i(0)$ determines the initial value of the i th variable for a country; $D_{i,\max}$ and $D_{i,\min}$ are the maximum and the minimum allowable values for the i th variable; rand is a random number in the interval [0, 1]. If the allowable search space is a discrete one, using a rounding function will also be necessary. For each country, the cost identifies its usefulness. In the optimization process, the cost is proportional to the cost function.

When the values of cost for initial countries are calculated, some of the best countries (in optimization

terminology, countries with the lower costs) will be selected to be the imperialist states and the remaining countries will form the colonies of these imperialists. The total number of initial countries is set to $N_{country}$ and the number of the most powerful countries to form the empires is equal to N_{imp} . The remaining N_{col} of the initial countries will be the colonies each of which belongs to an empire. All the colonies of initial countries are divided among the imperialists based on their power. The power of each country, the counterpart of fitness value, is inversely proportional to its cost value. That is, the number of colonies of an empire should be directly proportionate to its power. In order to proportionally divide the colonies among the imperialists, a normalized cost for an imperialist is defined.

Fig. 2 shows the movement of a colony towards the imperialist (assimilation). In this movement, θ and x are random numbers with uniform distribution as illustrated in (2) and d is the distance between colony and the imperialist [10].

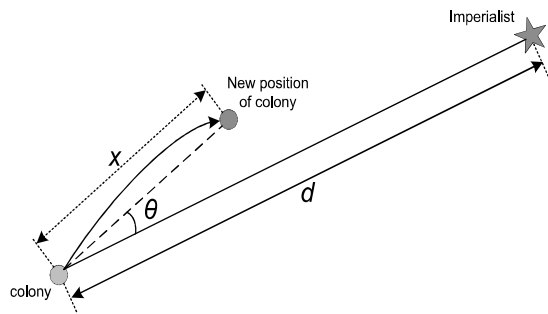

Fig. 2. Motion of colonies toward their relevant imperialist [10]

$$x \approx U(0, \beta \times d), \theta \approx U(-\gamma, \gamma) \quad (2)$$

Where, β and γ are parameters which randomly modify the area that colonies search around the imperialist.

It should be noted that the total power of an empire depends on both the power of the imperialist country and the power of its colonies [10], which is shown in (3).

$$T.C.n = Cost(Imperialist) + ICA \text{ mean}(Cost(Colonies \text{ of } Empire \ n)) \quad (3)$$

Furthermore, the main part of the algorithm which forms the formation of ICA technique is imperialistic competition among empires. In this step, powerful empires, take possession of weak empires' colonies. Finally, this competition converges to a state in which there exists only one empire. In this way the algorithm finds the optimum or near optimum answer.

4. Description of Case Study System

In this paper, a two-area, four-machine system is used as a test case (Fig. 3). In Fig. 3, L_1 and L_2 are loads. All

the generators are modeled in detail. And the simplified excitation system models are included. It is assumed that the generators are not equipped with power system stabilizers (PSS).

The HVDC link works in normal conditions in which the rectifier is in constant current control and the inverter is in constant extinction angle control. The parameters of the test-system come from [12]. The compensation capacity of the shunt capacitor in bus 3 is 600Mvar and in bus 15 is 100Mvar. HVDC link works in 500kV and transmits 100MW. It is obvious that the parameters of the DC-link (the voltage and transmitted power) are not realistic, but the purpose is not to design a controller for a real DC-segmented system and due to its usage in the literature and its accuracy, the test case, to a large extent, is remained intact.

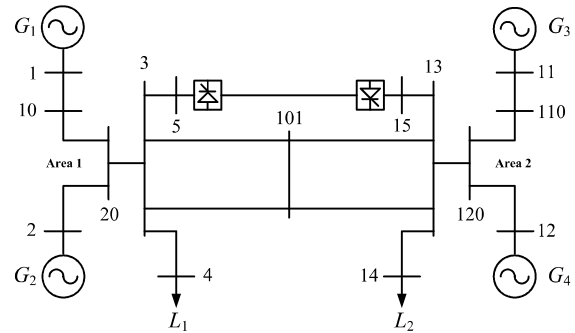

Fig. 3. Two-area test-system with an HVDC-link [12]

5. HVDC Supplementary Controller Design

The basic controlled quantity, in an HVDC transmission link, is the direct current, which is controlled by the rectifier whereas the dc line voltage is maintained near the rated value by inverter control [13]. The current order at the rectifier can be modulated to damp the AC system electromechanical oscillations.

Several works have been reported in the literature regarding HVDC supplementary controller design [14]-[23]. The works include wide range of controller design methodologies. Linear control theory along with an evolutionary optimization technique, as an advanced method of designing supplementary controllers, is being used in this paper.

Fig. 4 shows the transfer function diagram of the HVDC supplementary controller. The difference between voltage phase angles of the two areas in the test-system, i.e. buses 3 and 13, will be used as input signal, in order to respond to a global change.

In the proposed method, HVDC current modulation controller parameters are tuned optimally in order to improve overall system dynamic stability. To acquire



an optimal combination, this paper employs ICA to find the global optimum value of fitness function.

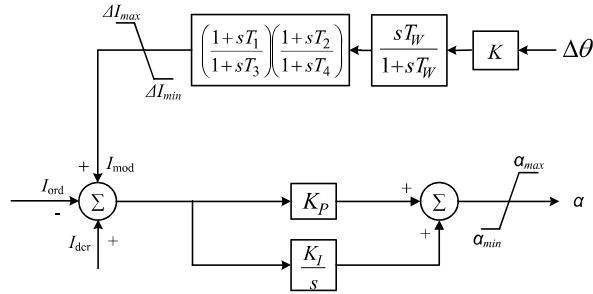

Fig. 4. Transfer function diagram of HVDC supplementary controller

Using the ICA technique, HVDC current modulation controller parameters, namely K , T_1 , T_2 , T_3 , and T_4 , are tuned optimally, to improve dynamic stability of system. In order to apply ICA technique to this problem, an eigenvalue based multi-objective function reflecting the combination of damping factor and damping ratio is considered as follows [24]:

$$J = J_1 + aJ_2 \quad (4)$$

Where,

$$J_1 = \sum_{\sigma_i \geq \sigma_0} (\sigma_0 - \sigma_i)^2 \quad (5)$$

$$J_2 = \sum_{\xi_i \leq \xi_0} (\xi_0 - \xi_i)^2 \quad (6)$$

σ_i and ξ_i are the real part and the damping ratio of the i -th eigenvalue. In this paper, the value of a is chosen as 10 [24]. It is necessary to mention here that only the unstable or lightly damped electromechanical modes of oscillations are relocated. The design problem can be formulated as the following constrained optimization problem, where the constraints are the controller parameters' bounds:

Minimize J subject to:

$$\begin{aligned} K^{\min} &\leq K \leq K^{\max} \\ T_1^{\min} &\leq T_1 \leq T_1^{\max} \\ T_2^{\min} &\leq T_2 \leq T_2^{\max} \\ T_3^{\min} &\leq T_3 \leq T_3^{\max} \\ T_4^{\min} &\leq T_4 \leq T_4^{\max} \end{aligned}$$

Typical ranges of the controller parameters are [-100, 100] for K , [-1.5, 1.5] for T_1 , T_2 , T_3 , and T_4 .

6. Simulation Results

Simulations are performed using Power System Toolbox (PST) [12] and obtained results are presented in two sections as follow:

6.1. ICA Implementation

The ICA is applied to search for the optimal parameters setting of the supplementary controller, so that the objective function is optimized. In this study, the values of σ_0 and ξ_0 are taken as -1 and 0.3, respectively. In order to acquire better performance, number of countries, number of initial imperialist, number of decades, assimilation coefficient (β), assimilation angle

coefficient (γ), and ζ_{ica} are chosen as 80, 8, 150, 3, 0.3 and 0.2, respectively.

Due to the large search space of the problem, the ICA is run 10 times and the optimal result is found among them. The final values of the optimized parameters are given in Table 1. T_W is taken as 10. Fig. 6 shows the cost versus iteration illustration of the ICA technique which is the mean cost of the 10 runs. It should be mentioned that the ICA is used offline to calculate the gain and time constants. The flowchart of the implemented optimization process is in Fig. 5.

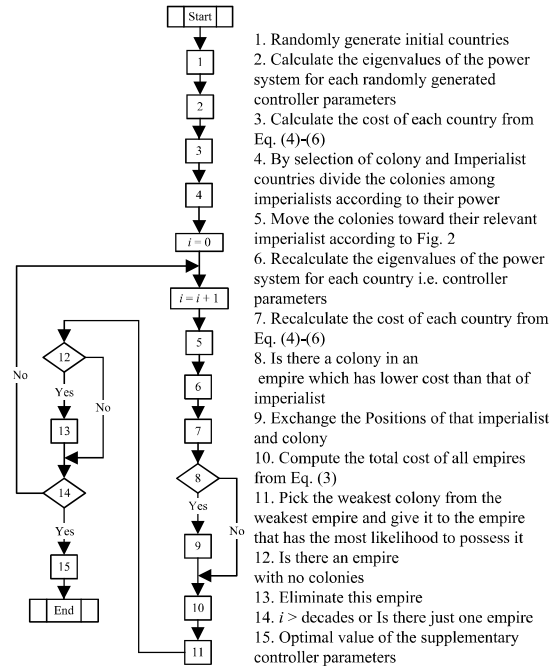

Fig. 5. Flowchart of the implemented ICA technique.

Table 1. Optimal parameters of the controller

K	T_1	T_2	T_3	T_4
-1.5100	0.8602	0.7280	0.0500	0.0500

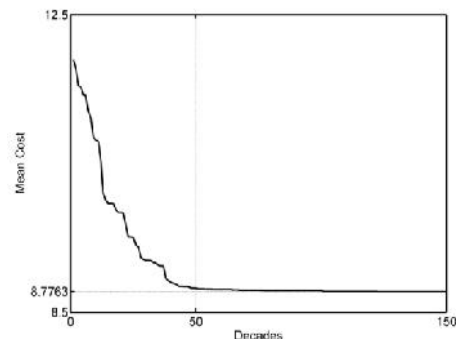

Fig. 6. Convergence illustration of ICA

The electromechanical modes of the system, with and without the supplementary controller are given in Table 2. It is clear that the system without the controller has an inter-area mode with extremely low

damping (0.96%). Applying the controller to the system, the damping is hopefully increased by nearly 17 times (16.90%). The improvement can also be seen from the other seemingly local modes. It should be noted that participation factor analysis showed that the first local mode is resulted from oscillations in machines of area 2, and other two modes from interaction of HVDC controller with machines in area 1.

Table 2. Electromechanical modes, with and without the controller

Without HVDC supplementary controller			
	Eigenvalue	f (Hz)	ζ (%)
Inter-area mode	$-0.0375 \pm j3.9102$	0.6223	0.96
Local modes	$-0.7888 \pm j6.9249$	1.1021	11.32
	$-0.7111 \pm j7.0441$	1.1211	10.04
With HVDC supplementary controller			
	Eigenvalue	f (Hz)	ζ (%)
Inter-area mode	$-0.6892 \pm j4.0195$	0.6397	16.90
Local modes	$-0.7137 \pm j7.0071$	1.1152	10.13
	$-1.9795 \pm j7.3644$	1.1721	25.96
	$-1.5829 \pm j7.6495$	1.2175	20.26

6.2. Time Domain Simulation

Loss of AC lines 3-101 parallel with HVDC link, at $t=40s$ is used as a method to simulate DC-segmentation (Fig. 7). In this way, a large disturbance can be simulated as well as system DC-segmentation. The operation of HVDC link between two segmented areas, without and with the supplementary controller, will be shown in two scenarios as follows:

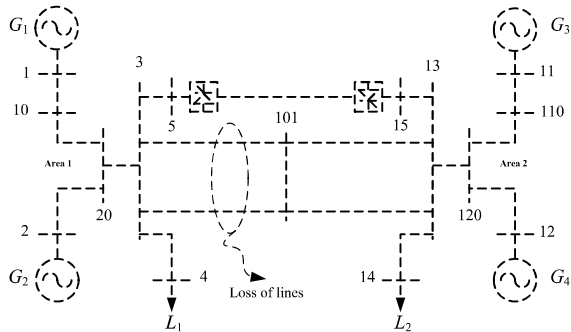

Fig. 7. Loss of lines parallel to DC-link; as a result, DC-segmentation of the system

6.2.1. Scenario 1, Without Supplementary Controller

In this scenario the DC-link between two areas remains intact and transmits its scheduled power. As Fig. 8 shows, after parallel AC lines elimination at $t=40s$, the two areas are DC-segmented and therefore machine-speeds oscillate and finally are forced to different values.

After being subjected to the disturbance, the transmitted active power through DC line does not change much and remains nearly constant in steady state (Fig. 9).

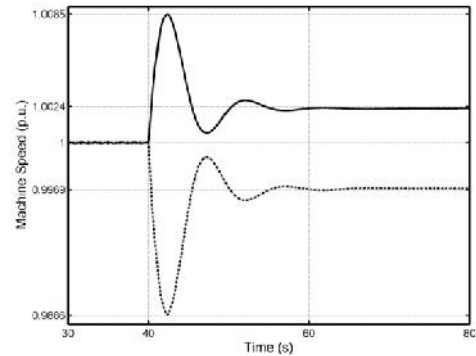

Fig. 8. Machine speeds in scenario 1 (solid: G_1 and dashed-dotted: G_3)

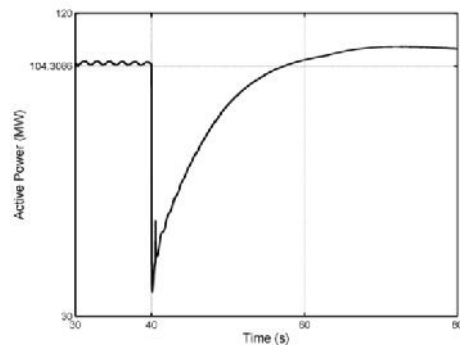

Fig. 9. Active power of DC-link in scenario 1

The system is stable, that is, the rotor angles of machines in both areas remain bounded as it is shown in Figs. 10-11. Area center of inertia (ACOI) [25] is used here in order to measure every machine's rotor angle with respect to its own area. It is due to the fact that DC connection between areas causes to the areas work asynchronously which is a sign of instability, however, the system in this new topology is stable. Therefore for DC-segmented systems, it is necessary to use ACOI as a reference to measure rotor angles.

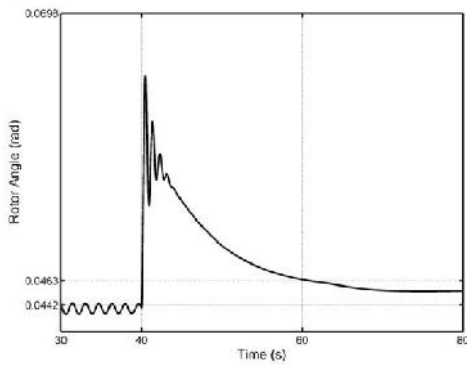

Fig. 10. Rotor angle of G_2 with respect to area 1 COI

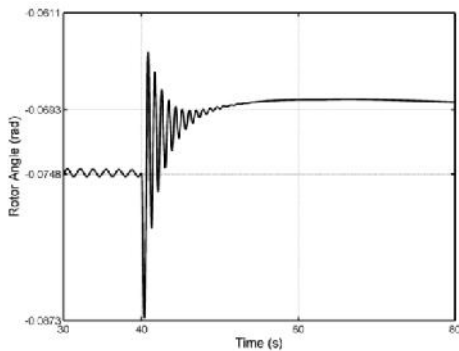

Fig. 11. Rotor angle of G_4 with respect to area 2 COI

The electrical powers produced by generators in two areas are shown in Figs. 12-13. The important point is that DC line transmits its fixed power near to 100 MW and the spinning reserve of area 2 responds to the disturbance in a way that helps the system to keep balance between generation and demand.

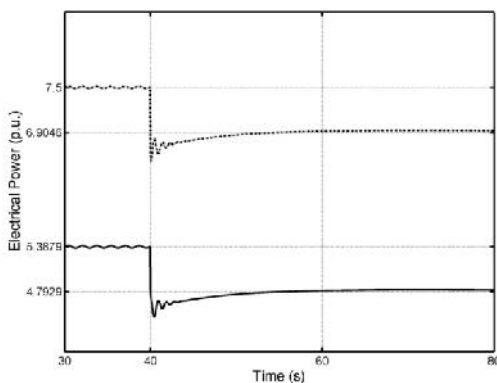

Fig. 12. Electrical power produced by generators in area 1 (solid: G_1 , dashed-dotted: G_2), scenario 1

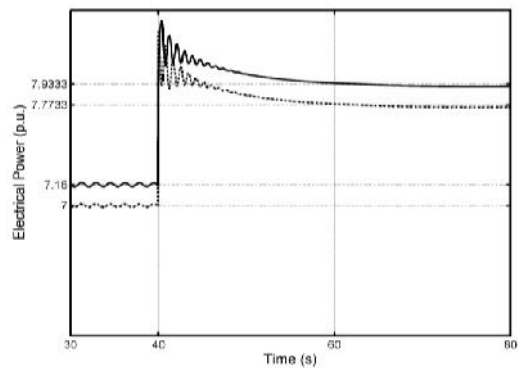

Fig. 13. Electrical power produced by generators in area 2 (solid: G_3 , dashed-dotted: G_4), scenario 1

6.2.2. Scenario 2, with supplementary controller

The designed controller for parallel AC-DC interconnected system is installed on the HVDC and simulation is repeated by elimination of parallel AC lines as shown in Fig. 7. The system is DC-segmented at $t=40s$. Due to the global nature of supplementary controller input, the two areas' generator-speeds, after being subjected to the loss of AC line, are damped and reached to the same value as illustrated in Fig. 14. This is because of the nearly fast response of DC-link, by changing the power level as shown in Fig 15.

The system is stable, that is, the rotor angles, relative to the area COIs, remain bounded. (Figs. 16-17.)

The electrical powers produced by generators in two areas are shown in Figs. 18-19. Loss of AC lines causes to active power transmission between two areas decrease but the presence of supplementary controller compensate for it and tunes the active power of DC-link. In this case the spinning reserves of the areas remain intact and this is desirable for systems without such an additional generation.

It can be seen that HVDC supplementary controller could be a good choice for DC-segmented systems under occurrence of disturbances, but it should be noticed that maximum power transmission of DC-links must be set considering the spinning reserve of the regions.

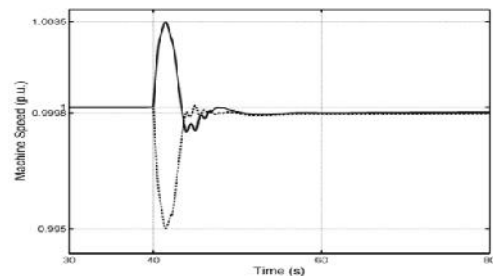

Fig. 14. Machine speeds in scenario 2 (solid: G_1 and dashed-dotted: G_3)

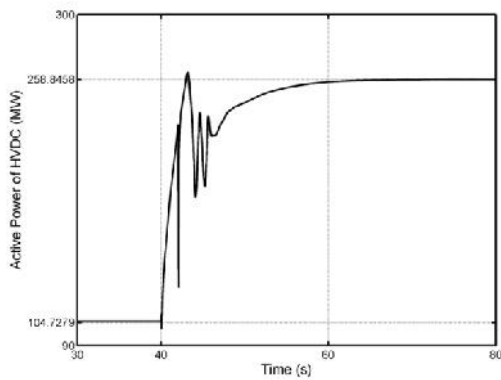

Fig. 15. Active power of DC-link in scenario 2

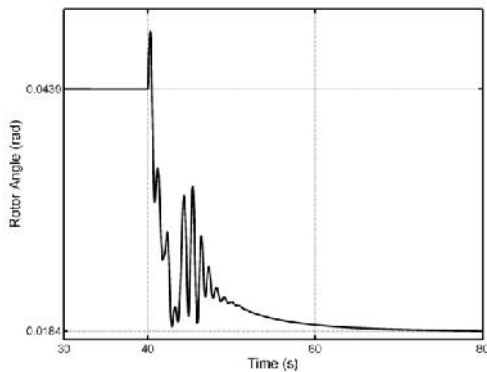

Fig. 16. Rotor angle of G_2 with respect to area 1 COI

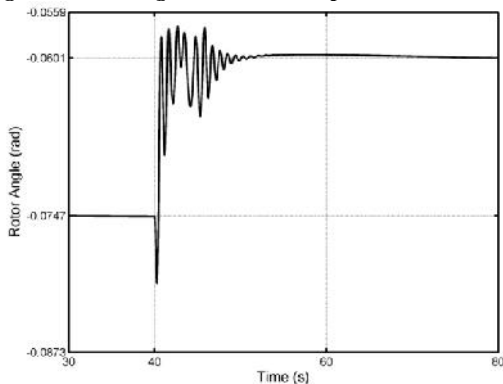

Fig. 17. Rotor angle of G_4 with respect to area 2 COI

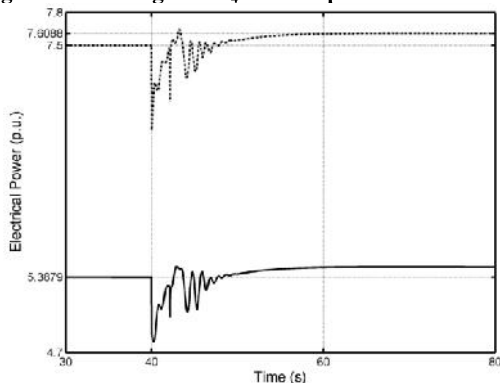

Fig. 18. Electrical power produced by generators in area 1 (solid: G_1 , dashed-dotted: G_2), scenario 2

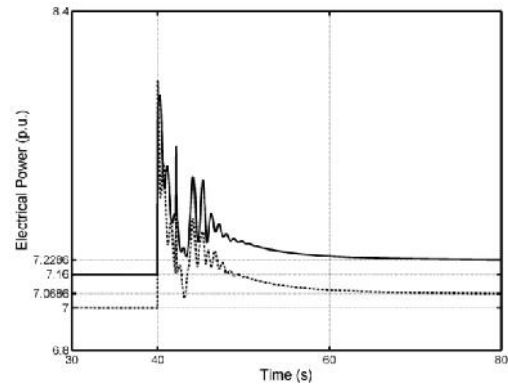

Fig. 19. Electrical power produced by generators in area 2 (solid: G_3 , dashed-dotted: G_4), scenario 2

7. Conclusion

In this paper, application of an HVDC supplementary controller in CSC-HVDC-segmented system was investigated. ICA was used in order to find the optimum or near optimum parameters of the controller. The results illustrated that HVDC supplementary controller can quickly respond to a large disturbance and maintain the two-area DC-segmented system stable. The work can be extended more by considering several DC-links in a multi-area system; Locating PSSs [26] and coordinating them with DC-links; analyzing system dynamics under HVDC related faults [27], modeling of robust controllers [28] for the converters, studying system state estimation under instabilities [29] and etc.

References

- [1] G.C. Loehr, "And there will be blackouts," keynote speech at T&D World Conference, Cincinnati, OH, 1999.
- [2] H.K. Clark, "It is time to challenge conventional wisdom," Trans. Distrib. World, 2004. <http://tdworld.com/mag/power_time_challenge_conventional>.
- [3] H.K. Clark, and D. Woodford, "Segmentation of the power system with DC links," IEEE HVDC-FACTS Subcommittee Meeting, Las Vegas, NV, 2006.
- [4] H.K. Clark, A.A. Edris, M.M. El-Gasseir, H.D. Epp, A. Isaacs, D. Woodford, "Softening the blow of disturbances," IEEE Power & Energy Magazine, pp. 30-41, 2008.
- [5] H.K. Clark, M.M. El-Gasseir, H.D. Kenneth, and A.A. Edris, "The application of segmentation and grid shock absorber concept for reliable power grids," in Proc. 12th International Power System Conference, MEPCON, pp. 34-38, 2008.
- [6] X. Fang, and J.H. Chow, "BTB DC link modelling, control, and application in the segmentation of AC interconnections," IEEE Power & Energy Society General Meeting, PES '09, Calgary, AB, 2009.
- [7] R.G. Roshanagh, S.N. Ravadanegh, "A way to evaluate segmentation: An examination of AC line elimination in a parallel AC/DC transmission system," In Electrical Engineering (ICEE), 2013 21st Iranian Conference on (pp. 1-4). IEEE, May 2013.
- [8] S.P. Azad, R. Irvani, J.E. Tate, "Damping low-frequency oscillations by tuning the operating point of a dc-



segmented ac system,” In Power and Energy Society General Meeting (PES), 2013 IEEE (pp. 1-5). IEEE, July 2013.

- [9] O.A. Mousavi, L. Bizumic, R. Cherkaoui, “Assessment of HVDC grid segmentation for reducing the risk of cascading outages and blackouts,” In Bulk Power System Dynamics and Control-IX Optimization, Security and Control of the Emerging Power Grid (IREP), 2013 IREP Symposium (pp. 1-10). IEEE, August 2013.
- [10] E. Atashpaz-Gargari, and C. Lucas, “Imperialist Competitive Algorithm: An algorithm for optimization inspired by imperialistic competition,” in Proc. IEEE Congress on Evolutionary Computation, Singapore, pp. 4661-4667, 2007.
- [11] A.A. Edris, L.O. Barthold, D.A. Douglas, and D. Woodford, “Upgrading AC transmission to DC for maximum power transfer capacity,” in Proc. 12th International Power System Conference, MEPCON, pp. 44-49, 2008.
- [12] J.H. Chow, and G. Rogers, Power system toolbox user’s manual, PST version 3.0, Ontario, Canada, 2008. <www.etk.ee.kth.se/personal/vanfretti/pst/Power_System_Toolbox_Webpage/PST.html>
- [13] P. Kundur, “Power system stability and control,” McGraw-Hill Inc., New York, p. 1151, 1994.
- [14] K.K.Y. Poon, Z. Lan, H. Zhu, Y. Ni, “Application of a coordinated optimization algorithm for controller parameter tuning of HVDC power modulation control,” IEEE Power Engineering Society General meeting, Tampa, FL, 2007.
- [15] H. Liu, Z. Xu, L. Jin, “Coordination and optimization of small signal modulators in multi-infeed HVDC systems,” in Proc. Transmission and Distribution Conference and Exposition IEEE PES, Vol.1, pp. 35-40, 2003.
- [16] Y. Chang, H. Chen, and F. Zhang, “Design of multi-objective robust HVDC supplementary controller based on global signal,” in Proc. Power Systems Conference and Exposition PSCE '06. IEEE PES, pp. 2146-2151, 2006.
- [17] C. Li, M. Watanabe, Y. Mitani, “HVDC controller design for damping of inter-area oscillation using synchronized phasor measurements and bacteria foraging algorithm,” International Conference on Electrical Engineering, Shenyang, China, 2009.
- [18] Y. Huang, and Z. Xu, “HVDC supplementary controller based on synchronized phasor measurement Units,” in Proc. Power Systems Conference and Exposition, IEEE PES, Vol.2, pp. 668-672, 2004.
- [19] S. Haidari, M.M. Farsangi, H. Nezamabadi-pour, and K.Y. Lee, “Design of supplementary controller for HVDC using memetic algorithm with population management,” IEEE Power Engineering Society General Meeting, Pittsburgh, PA, 2008.
- [20] T. Smed, G. Andersson, “Utilizing HVDC to damp power oscillations,” IEEE Trans. Power Del, Vol.8, No.2, pp. 620-627. 1993.
- [21] W. Juanjuan, F. Chuang, Z. Yao, “Design of WAMS-based multiple HVDC damping control system,” IEEE Trans. Smart Grid, Vol.2, No.2, pp. 363-374, 2011.
- [22] M. Xiao-Ming, Z. Yao, “Application of HVDC modulation in damping electromechanical oscillations,” IEEE Power Engineering Society General Meeting, pp.1-6, 2007.
- [23] J. He, C. Lu, X. Wu, P. Li, J. Wu, “Design and experiment of wide area HVDC supplementary damping controller considering time delay in China southern power grid,” Gener. Transm. Dis., IET, Vol. 3, No. 1, pp. 17-25, 2009.
- [24] H. Shayeghi, H.A. Shayanfar, S. Jalilzadeh, and A. Safari. “A PSO based unified power flow controller for damping of power system oscillations,” Energy conversion and management, Vol.50, No.10, pp. 2583-2592, 2009.
- [25] Y. Ni, Z. Lan, L. Zhu, K.K.Y. Poon, D. Gan, H. Zhu, and Z. Cai, “Area center of inertia—a potential unified signal for synchronous and frequency stability control of interconnected power systems under short and long time spans,” International Conference on Electrical Engineering, Kowloon, Hong Kong, 2007.
- [26] A. Karimpour, R. Asgharian, N. Pariz, H. Khaloozadeh, O.P. Malik, “Determination of PSS location based on the control structure design indices,” Journal of Iranian Association of Electrical and Electronics Engineers, Vol.1, No.3, pp. 15-23, 2005.
- [27] A. Shoulaie, S.E. Jafarabadi, “Analysis, modelling and simulation of HVDC transmission line internal overvoltages,” Journal of Iranian Association of Electrical and Electronics Engineers, Vol.1, No.3, pp. 11-22, 2005. (in persian)
- [28] M. Dehghani, S.K.Y. Nikravesh, M. Karrari, “Decentralized robust power system stabilizer design,” Journal of Iranian Association of Electrical and Electronics Engineers, Vol.4, No.1, pp. 36-43, 2007.
- [29] H. Asadi, M. Sanaye-Pasand, M. Davarpanah, “Introducing a novel method for real time estimation of power system voltage instability based on wide area Protection,” Journal of Iranian Association of Electrical and Electronics Engineers, Vol.4, No.2, pp. 3-13, 2007. (in persian)