

Transient Stability Enhancement in Microgrids Including Inverter Interfaced Distributed Generations

S. Shokoohi¹

H. Bevrani²

J. Moshtagh³

S. Ahmadi⁴

¹ MSC -Instrumentation and Control Unit, Iranian Oil Pipelines and Telecommunication Company, Kermanshah, Iran
shokoohi@ieee.org

² Associate Professor -Department of Electrical and Computer Engineering, Faculty of Electrical Engineering, University of Kurdistan, Sanandaj, Iran
bevrani@ieee.org

³ Assistant Professor -Department of Electrical and Computer Engineering, Faculty of Electrical Engineering, University of Kurdistan, Sanandaj, Iran
Moshtagh_79@yahoo.com

⁴ Bachelor of Science -Department of Electrical and Computer Engineering, Urmia University, Urmia, Iran
Salehahmadi66@yahoo.com

Abstract :

With increasing the presence of Microgrids (MGs) in the power systems, investigating the MG stability during transient faults is necessary. This study investigates the transient stability analysis of a MG supplied by multiple inverter interfaced distributed generations (IIDGs) during fault. The transient stability of a MG is highly depends on the IIDGs control strategy. A MG, simulated on Matlab/Simulink, including three IIDGs and two local loads connected to the IEEE 37-node distribution system is considered as test system. Simulation results show that the MG may lose its stability due to the IIDG's transient over-currents during fault. By adding a transient current control loop to the voltage source inverter (VSI) control strategy, the IIDG's output currents are limited during fault. In the connected mode, an external fault is applied to the MG. By using an appropriate tuning based on fuzzy logic method, the transient loop controller coefficients is optimally tuned. The simulations results show the good performance and fast dynamic of the proposed control approach; also the transient stability enhancement of the MG, obviously.

Keywords: Transient stability, Inverter interfaced distributed generation, Fault current, Generalized droop control, Transient control loop, and Modulation index.

Submission date : 25, Nov, 2013

Conditionally acceptance date: 1, Sep., 2014

Acceptance date : 2, July, 2015

Corresponding author : S. Shokoohi

Corresponding author's address: Kermanshah, Iranian Oil Pipelines and Telecommunication Company (IOPTC)-Kermanshah Branch, Kermanshah, Iran.

1. Introduction

A microgrid (MG) is a complex of distributed generations (DGs) that are working together for transferring a confident, economical, and environmental power. Renewable energy sources (RESs) penetration is rapidly increasing in the distribution systems. The MGs have advantages such as reducing environmental problems, reducing the costs of constructing a new power plant, and increasing system reliability. But, it cause some new problems in the power system such as changing power flow pattern, increasing high frequency harmonics due to use of power electronic devices; and increasing frequency and voltage fluctuations due to variable nature of RESs [1-3].

Generally, the MGs have two steady operating modes: grid connected and islanded modes. These steady modes with transient modes are shown in Fig. 1. A MG is normally connected to the main grid to participate in the control planning and electric market policies. If a disturbance occurs in the distribution system so that the reliable generated power not delivered to the customer, the protection systems are activated, and the MG is separated from the distribution system to supply the local loads, autonomously [4]. If a severe event occurs following a contingency forth of the MG, it is possible that the MG cannot switch into islanded mode and it is collapsed. In addition, one of the challenges towards the MG designers is disconnecting a MG from the main grid in a stable manner in order to control the system voltage and frequency. The MGs should be capable to manage the rapid changes of voltage and frequency even when the generated power is less than the local loads. Also, before connecting the MG to the main grid, a synchronization process is necessary [5].

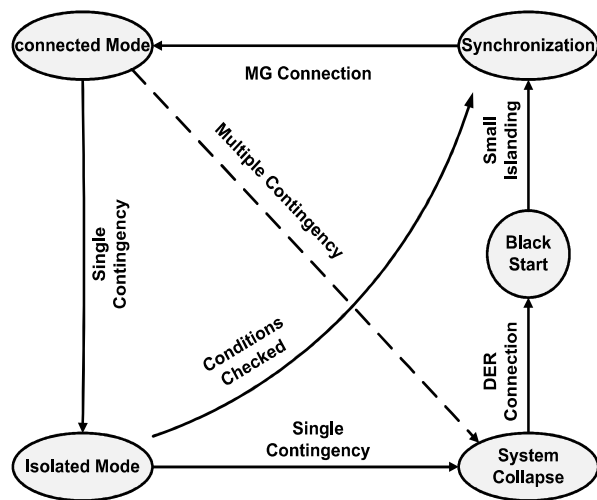

Fig. 1. Transient and steady state modes of an MG

2. Transient Stability in MGs

When a major disturbance occurs in the system, the system state variables are rapidly receded from their nominal values. Immediately after the disturbance, the system's ability to reach an acceptable steady-state operating condition is called transient stability [6]. Transient stability is categorized as a short-term phenomenon and transient instability usually manifests as first swing instability [7]. According to IEEE definition [8], a power system is transiently stable for a specific steady-state operating condition and under a specific major disturbance, if it reaches to an acceptable steady-state operating condition. When a fault happens in the system, due to being low active power output during fault, the rotor speed deviation of synchronous generators is rapidly increased but the governor reaction speed is not fast enough. The amount of increasing the rotor speed is depends on the distance between generator and fault location. Whatever the generator distances from the fault location is less; the intensity of speed changes is more. Increasing the rotor speed during fault leads to the governor reaction, but this reaction is not adequately quick and the voltage collapses extremely. If the fault is removed at a time less than the critical time of the system, the rotor speed decreases gradually and finally comes back to the nominal range. Thus, the rotor speed can be selected as an index to evaluate the transient stability of synchronous generators.

Due to different dynamic of RESs in comparison with traditional resources, concept of transient stability in the MGs is different with traditional power systems [9]. In traditional power systems, critical time is a suitable index to evaluate the transient stability. The maximum time between the fault initiation and the fault clearing that the distribution system can remains in the stable state, is named critical time. Due to the existence of power electronic equipment and switching devices in the MGs, if the MG's protection system is not appropriately designed, it can leads to negative effects on critical time and some challenging problems such as increasing the fault current. When a fault occurs in the distribution system, the MG should be quickly isolated from the main grid to supply the required power of local loads. If the islanding process is not quickly done, due to the negative effects of faults on the DGs output current, number of the DGs may be failed and the MG will be collapsed. The maximum time between fault initiation and islanding initiation that the MG remains transiently stable, is the critical switching time (CST) [10].

3. Inverter interfaced distributed generations

There are two basic classes of distributed energy resources (DERs). One is a DC resources such as fuel cells and photovoltaic cells; and the other is high frequency AC resources such as micro turbine, which needs to be rectified. In both cases, the resultant DC voltage is converted to an acceptable AC source using an inverter. Therefore, a power electronic interface is necessary to convert DC to AC [11]. These types of DERs which are connected to MG by means of inverter are named inverter interfaced distributed generations (IIDGs) [12].

The general schematic of an IIDG is shown in the Fig 2. An IIDG is composed of prime mover, DC interface and DC to AC converter. The prime mover can be a fuel cell, a photovoltaic cell or a rectified output of other high frequency DERs. Due to fluctuating nature of DERs, the DC output voltage is not completely fixed. Thus, a storage system is used between the prime mover and the inverter [13]. The task of the storage devices is based on the equilibrium between generation and consumption. In fact, the storage devices play the same task of spinning reserve in traditional power systems. Due to existence of the power storage interface during transients, the prime mover dynamics can be ignored [12].

The most important advantage of IIDGs is their quick response to change in the output. If a change happens in the MG, the IIDGs can quickly compensate it. But, this fast response to the changes has some bad effects on the fault current [14]. During an event, the IIDG response basically is depend on the inverter control structure [12].

To prevent damaging of switching devices used in the inverters, IIDGs are usually equipped by instantaneous over-current shutdown protection. If an intense over-current transmits through the switching devices for more than several microseconds, the over-current protection activates and decreases the output current to zero in less than a millisecond [14].

The results show that the voltage falls significantly in the first cycle after occurring fault, and then reaches a constant value and the fault current will increase rapidly. Due to slight changes in power during a fault and averaging in power calculation, the voltage source inverter (VSI) controller cannot reduce the fault current peak during sub-transient period (first cycle) and transient period (between 3rd and 10th cycles) [12]. The only constraint which can be lead to the instability of the IIDGs is passing fault current more than the maximum tolerable power of the switching devices. In practical, instantaneous over-current protection is designed so that if current reaches to twice of the nominal value, the VSI is failed [15]. So, the short-circuit currents of IIDGs can be defined as an index to evaluate the transient stability of MGs.

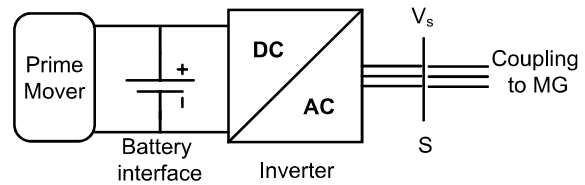

Fig. 2. Basic Parts of an IIDG

4. Transient Mode Control Design

Recently, in order to consider the simultaneous impacts of active and reactive power fluctuations on the MGs' voltage and frequency, a generalized droop control (GDC) structure based on line parameters has been presented in [16] (Fig. 3). In this structure, the active and reactive powers are simultaneously used to compensate the voltage and frequency droops after any change in load. In Fig. 3, K_f and K_V are droop coefficients and K_R is an index to show what percentage of line is resistive. The GDC presents a more real model for droop control in the IIDGs. Due to averaging in calculating active and reactive output powers of the inverter (P and Q), it is expected that the GDC cannot restricts the output current of IIDG during fault duration.

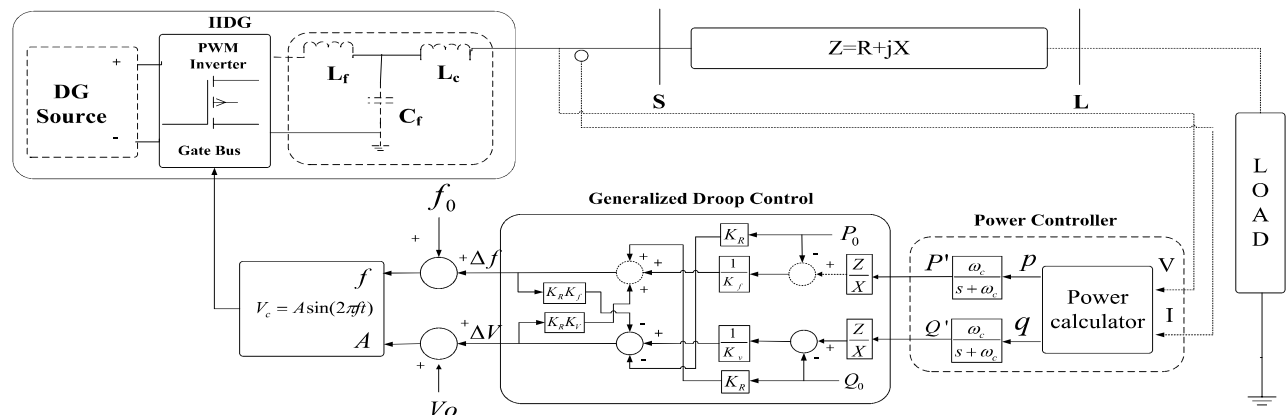

Fig. 3. An IIDG and generalized droop control [16]



Consider the MG shown in Fig. 4. This MG includes three IIDGs and two local loads. The MG is connected to the IEEE 37 nodes test Feeder [17] in the node 775 (Fig. 5). To analyze the transient behavior of the GDC, the first cycles of the output voltage and current of IIDGs should be studied during fault in the distribution system. In the connected mode, the voltage amplitude and frequency of the node 775 and in the isolated mode, the nominal values (220v and 50Hz) are selected as the reference value [18].

In order to check the performance of the GDC in transients, the bypass switch located between node 775 and MG will stay connected during fault, and also the fault will not be removed. At time 0.5s, a three phase fault is occurred in node 703. The output current and voltage of the IIDGs are shown in Figs. 6 and 7. As shown, the output currents of IIDG1 and IIDG2 exceed from twice nominal value at the first cycle (sub-transient period) after time 0.5s. But, due to more distance from node 775, the output current of IIDG 3 does not exceed from the critical limit (twice nominal current of each IIDG). Fig. 6 shows that the GDC structure is not efficient during fault and before disconnecting bypass switch, due to being activate instantaneous protection system of inverter; the IIDG1 and IIDG2 is failed in less than a few milliseconds. Therefore, the MG will collapse after disconnecting bypass switch (islanded mode).

During fault condition, violent current deviations occur at the sub-transient period. Thus, if this deviations are converted to the voltage deviations range by a proportional-integral (PI) controller and are added to the voltage droop control, the GDC response speed to the events can be increased. The transient control loop should be designed in such a way that does not affect the IIDGs output in the steady/quasi-steady states and can decrease the output current of IIDGs at the sub-

transient period. The proposed transient loop has been shown in Fig. 8. In Fig. 8, the output current derivative is sampled. Then, in order to decrease current deviations to zero value; the root means square (rms) of output current derivative is added to the voltage droop control loop by passing through a traditional PI controller. The proposed transient control loop performance is only restricted to transient conditions. This restriction is applied by placing a dead zone before PI controller (see Fig. 8). By proper selecting of minimum and maximum value of the dead zone, the transient control loop do not no impact on the control structure of IIDGs (given in Fig. 3) in the normal conditions; but it is added to the voltage droop control loop only during sudden disturbances such as isolating of MG from main grid and outage of an IIDG in the isolated mode because the output current variations of IIDGs be more during contingency conditions. Existence this dead zone restrains interaction between control strategies of normal and contingency modes.

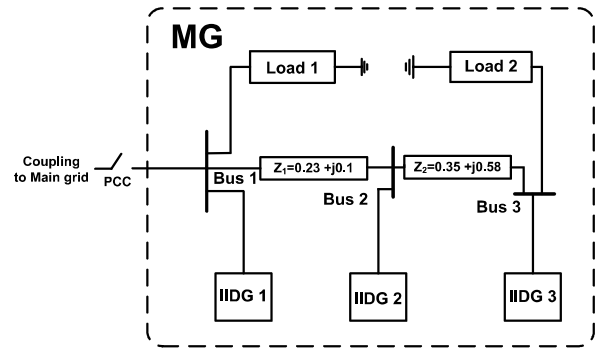

Fig. 4. A MG with two loads and three IIDGs

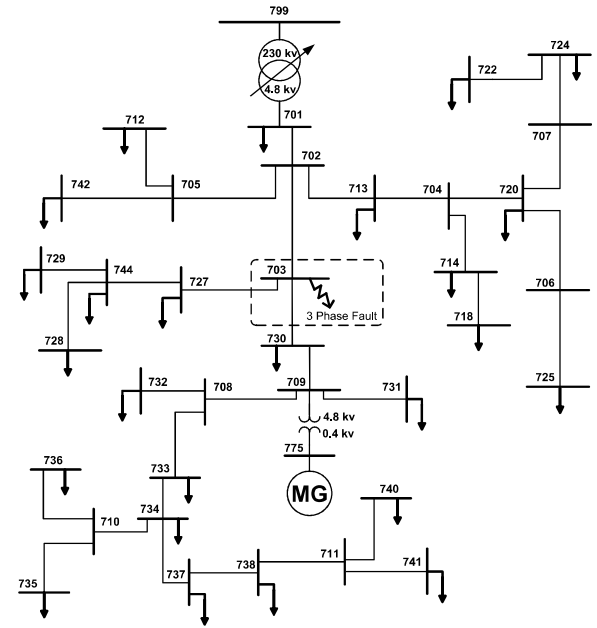

Fig. 5. IEEE 37 nodes test Feeder with a MG

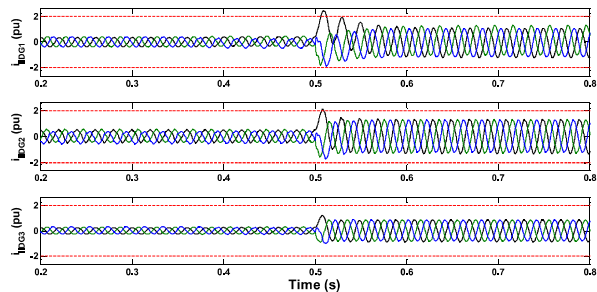

Fig. 6. IIDGs output current during fault conditions

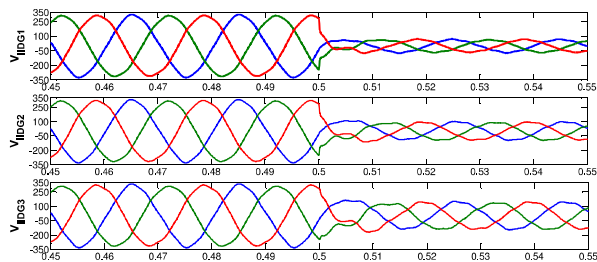

Fig. 7. IIDGs output voltage during fault conditions

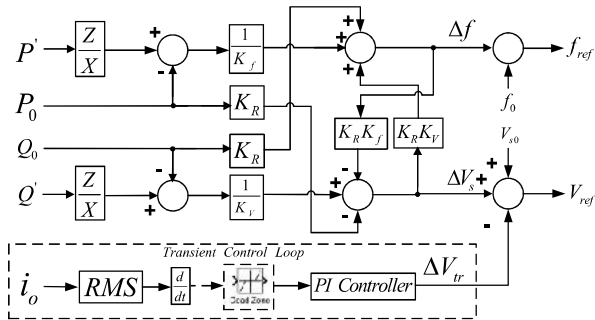

Fig. 8. Adding transient control loop to the GDC

To achieve a structure with well performance, the fuzzy logic (FL) is used as an intelligent method for tuning of the PI controller parameters. A FL system is composed of four sections: fuzzification, fuzzy rule base, inference system, and defuzzification [19]. A general map for FL based tuning of PI parameters is shown in Fig. 9. The proposed control framework consists of two stages: a traditional PI controller and a FL unit [20]. As shown in Fig. 9, the FL unit uses voltage deviation and current derivative to tune the PI control parameters. In order to apply the FL to the inverter control framework for adjusting of transient PI controller, a fuzzy rules set consisting of 18 rules is used to map input variables (Δv and $\frac{di}{dt}$) to output variables (K_p and K_i). The antecedent parts of each rule are composed by using AND function. The FL rules are given in Table. 1 and Table. 2. The membership functions determination (fuzzification step) obtain from the system structure and for another test case could be different. However, fuzzy rules that yield an output to determine the PI values are defined by trial-and-error method. The triangular membership functions are arranged as EVL (Extremely Very Large), VL (Very large), Large (L), Normal (N), High (H), VH (Very High), and EVH (Extremely Very High). The input/output membership functions are shown in Fig. 10. Here, Mamdani fuzzy inference system is used. Finally, the adjusted K_p and K_i parameters are obtained 0.0065 and -0.0055, respectively.

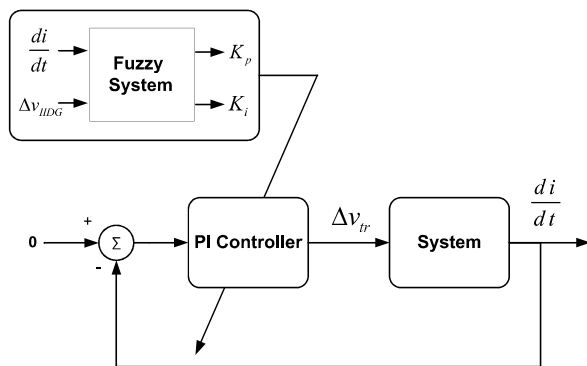

Fig. 9. Fuzzy PI based transient control loop

Table. 1. Fuzzy Rules Set for K_p

Δv \ $\frac{di}{dt}$	EVL	VL	L	H	VH	EVH
L	EVL	VL	L	H	VH	EVH
N	EVL	VL	L	H	VH	EVH
H	VL	L	H	VH	EVH	EVH

Table. 2. Fuzzy Rules Set for K_i

Δv \ $\frac{di}{dt}$	EVL	VL	L	H	VH	EVH
L	L	L	L	L	L	L
N	N	N	N	N	N	N
H	H	H	H	H	H	H

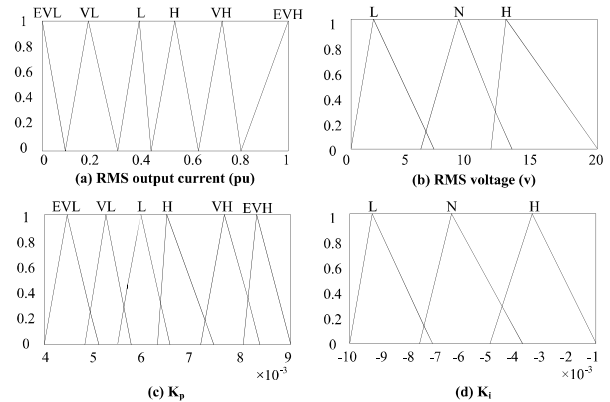

Fig. 10. Input/output fuzzy membership functions. a) Current derivative (pu), b) Voltage deviation (Δv), c) Integral Coefficient (K_i) and d) Proportional Coefficient (K_p)

After applying the transient control loop tuned by FL system, the IIDGs output current peak is decreased during sub-transient/transient state (see Fig. 11). As shown in Fig. 11, due to proper performance of the transient control loop, none of IIDGs is failed. Therefore, the MG can stably supply local loads in the isolated mode whenever the bypass switch acts. To ensure being isolated of the steady/quasi-steady state mode control from transient mode control, it is necessary to compare the MG's voltage profile in these two modes. With comparison of Figs. 7 and 12, before and after applying the transient control loop, no considerable impact is seen on the voltage profile before fault occurrence. Fig. 13 shows the performance of the proposed transient loop. In Fig. 13, IIDG1's modulation index is shown for both modes: with and without transient control loop. In first cycle after fault, due to severe deviations in the output current; the transient control loop is quickly activated. The proposed transient loop acts as an online protection system and causes to severe decrease of the modulation index in first cycle after occurring fault. But, the pure GDC has not a considerable impact on the modulation index during the fault. In fact, the transient control loop



decreases the voltage reference when the output current deviations are high. Being same of modulation index for both modes of “with” and “without” transient control loop before time 0.5s guarantees that the designed transient control loop has no considerable impact on the GDC performance in the steady/quasi-steady state conditions.

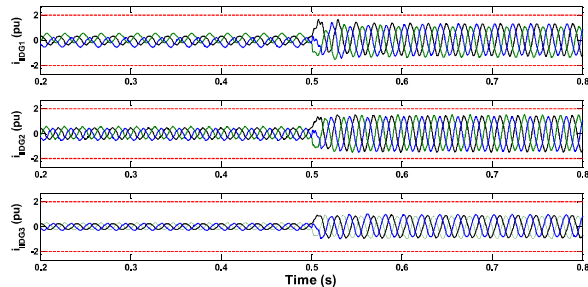

Fig. 11. IIDGs output current during fault conditions with adding fuzzy PI based transient control loop to the GDC

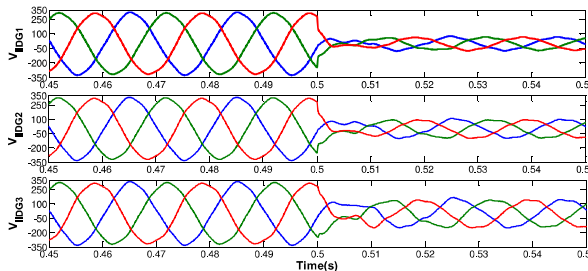

Fig. 12. IIDGs output voltage during fault conditions with adding fuzzy PI based transient control loop to the GDC

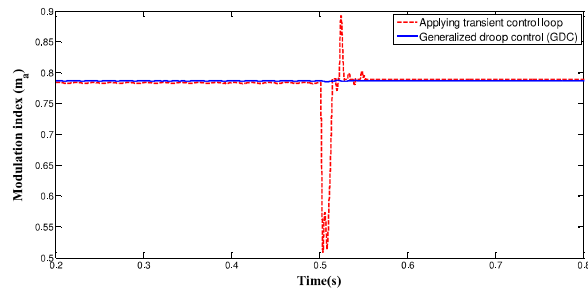

Fig. 13. Comparison of modulation index profile for both modes: with transient control loop and without transient control loop (only GDC)

5. Conclusion

In this paper, an important issue named transient stability of microgrids (MGs) during fault and disconnecting from the main grid is studied. In practice, if the output current of the inverter interfaced DGs (IIDGs) exceeds from twice nominal current, the inverter is failed. After fault and at the sub-transient/transient period, possibility of inverter failing due to cross the current from the twice nominal value is high. By failing IIDGs, MGs cannot be stably isolated and will be collapsed. In response to this challenge, in the present paper, a transient control method is used to limit the current deviations of IIDGs. This proposed

method has two levels including a classical PI controller and a fuzzy system which adjusts the parameters of the PI controller. To test the performance of the proposed transient method, a fault scenario on the IEEE 37 nodes test feeder is considered. The performed simulation test demonstrates the effectiveness of the proposed transient control technique for increasing reliability of MGs after severe or multiple events.

References

- [1] A. Hesami, F. Habibi, H. bevrani, "Robust control design for stabilizing of microgrid voltage in different operating conditions", Journal of Iranian Association of Electrical and Electronics Engineers, Vol. 10, No.1, pp. 23-32, 2013
- [2] S. Jadid, O. Homaei, and A. Zakariazadeh, "Voltage Control Approach in Smart Distribution Network with Renewable Distributed Generation", Journal of Iranian Association of Electrical and Electronics Engineers, Vol. 10, No. 2, pp. 11-21, 2014.
- [3] H. Vahedi, R. Noroozian, A. Jalilvand, G. B. Gharehpetian, "Introducing a New Method for Operation and Islanding Detection of Inverter-Based Distributed Generation", Journal of Iranian Association of Electrical and Electronics Engineers, Vol. 8, No. 2, pp. 25-33, 2011.
- [4] H. Bevrani, F. Habibi, and S. Shokoohi, "ANN-Based Self-Tuning Frequency Control Design for an Isolated Microgrid", Meta-Heuristics Optimization Algorithms in Engineering, Business, Economics, and Finance, pp. 357-385, 2012.
- [5] J. C. Vasquez, J. M. Guerrero, J. Miret, M. Castilla, and L. G. De Vicuna, "Hierarchical control of intelligent microgrids", Industrial Electronics Magazine, IEEE, vol. 4, pp. 23-29, 2010.
- [6] P. Varaiya, F. F. Wu, and R.-L. Chen, "Direct methods for transient stability analysis of power systems: Recent results", Proceedings of the IEEE, vol. 73, pp. 1703-1715, 1985.
- [7] P. Kundur, J. Paserba, V. Ajarapu, G. Andersson, A. Bose, C. Canizares, N. Hatziaargyriou, D. Hill, A. Stankovic, and C. Taylor, "Definition and classification of power system stability IEEE/CIGRE joint task force on stability terms and definitions", Power Systems, IEEE Transactions on, vol. 19, pp. 1387-1401, 2004.
- [8] IEEE Committee Report, "Proposed Definitions of Terms for Reporting and Analyzing Outages of Electrical Transmission and Distribution Facilities and Interruptions", Power Apparatus and Systems, IEEE Transactions on, vol.PAS-87, no.5, pp.1318-1323, May 1968.
- [9] F. Katiraei and M. Irvani, "Transients of a Micro-Grid system with multiple distributed energy resources", in Proc. of the international conf. on Power System Transients (IPST05), 2005.
- [10] Xinhe Chen; Wei Pei; Xisheng Tang; , "Transient stability analyses of micro-grids with multiple distributed generations", Power System Technology (POWERCON), 2010 International Conference on , vol., no., pp.1-8, 24-28 Oct. 2010.

- [11] R. H. Lasseter, "Microgrids", in proc. IEEE PES'02 Winter Meeting, 2002, Power Engineering Society Winter Meeting, 2002, pp. 305- 308.
- [12] M.E. Baran and I. El-Markaby, "Fault analysis on distribution feeders with distributed generators", IEEE Trans.Power Syst., vol. 2, no. 4, pp. 945–950, November 2005.
- [13] Jaehong Kim; Junggi Lee; Kwanghee Nam; , "Inverter-Based Local AC Bus Voltage Control Utilizing Two DOF Control", Power Electronics, IEEE Transactions on , vol.23, no.3, pp.1288-1298, May 2008.
- [14] S.R. Wall, "Performance of inverter interfaced distributed generation", in IEEE/PES Transmission and Distribution Conference Exposition, October 2001, vol. 2, pp. 945–950.
- [15] J. Keller and B. Kroposki, "Understanding fault characteristics of inverter-based distributed energy resources", Tech. Rep. NREL/TP-550- 46698, National Renewable Energy Laboratory, January 2010.
- [16] H. Bevrani and S. Shokoohi, "An Intelligent Droop Control for Simultaneous Voltage and Frequency Regulation in Islanded Microgrids", Smart Grid, IEEE Transactions on , vol.4, no.3, pp.1505,1513, Sept. 2013.
- [17] Radial Test Feeders—IEEE Distribution System Analysis Subcommittee. [Online]. Available: <http://ewh.ieee.org/soc/pes/dsacom/testfeeders.html>
- [18] J. M. Guerrero, J. C. Vasquez, J. Matas, L. G. de Vicuña, and M. Castilla, "Hierarchical control of droop-controlled AC and DC microgrids—A general approach toward standardization", IEEE Transactions on Industrial Electronics, vol. 58, pp. 158–172, 2011.
- [19] J. M. Mendel and G. C. Mouzouris, "Designing fuzzy logic systems", IEEE Trans. Circuits Syst. II, Analog Digit. Signal Process, vol. 44, pp. 885–895, Nov. 1997.
- [20] S. Ahmadi, S. Shokoohi, and H. Bevrani, "A fuzzy logic-based droop control for simultaneous voltage and frequency regulation in an AC microgrid", International Journal of Electrical Power & Energy Systems, vol. 64, pp. 148-155, 2015.



