

Novel Auxiliary Power Unit Configuration Based On Fuel Cell Technology for Civil Aircraft Application

Hamid Radmanesh¹ **Reza Sharifi²** **Amin Radmanesh¹** **Seyed Hamid Fathi²**
Assistant Professor, Electrical Engineering Department, Islamic Azad University, Central Tehran Branch, Tehran, Iran¹
h.radmanesh@iauctb.ac.ir
Ph. D., Electrical Engineering Department, Amirkabir University of Technology, Tehran, Iran²
Reza.sharifi@aut.ac.ir
M.S., Electrical Engineering Department, Shahid Sattari Aeronautical University of Science and Technology, Tehran, Iran³
radmanesh.amin130@yahoo.com
Professor, Electrical Engineering Department, Amirkabir University of Technology, Tehran, Iran⁴
fathi@aut.ac.ir

: Abstract

This paper proposes novel Fuel Cell Auxiliary Power Unit (FCAPU) for J150+ aircraft application. The primary engine version of APU in J150+ aircraft is a gas turbine Auxiliary Power Unit (APU) which is based on gas turbine technology. But in the suggested FCAPU, the generated electrical power is achieved from chemical energy with higher efficiency. The Solid Oxide Fuel Cell (SOFC) technology is used to generate the electrical energy and MATLAB software is applied to simulate the SOFC performance in the J150+ aircraft. The simulation results show the FCAPU ability to generate the proper electrical energy with lower cost and higher reliability in comparison with the ordinary APU. Index Terms - Auxiliary Power Unit, Generator, Fuel Cell, Aircraft

Submission date: 22, April, 2015

Conditionally Acceptance date: 30, Dec., 2015

Acceptance date: 31, July, 2016

Corresponding author : Hamid Radmanesh

Corresponding author's address: Electrical Engineering Department, Shahid Sattari Aeronautical University of Science and Technology, Tehran, Iran



1. Introduction

Aircraft is one of the growing sources of greenhouse gas emissions. The European Union is going forward to decrease aircraft emissions [1-2]. On the other hand, there is increasing interest about "more-electric" aircraft. The idea of More Electric Aircraft (MEA) is to replace the pneumatic and hydraulic systems with electrical power. The move towards MEA has been directed using larger power generation which leads to more gas emissions. Auxiliary power unit (APU) is a gas turbine mounted usually in the tail of the aircraft. A large part of total emissions of an aircraft is produced by the APU. APU is not efficient and is large sources of heat and emissions [1]. One of the purposes of APU is providing electrical energy (115VAC, 400Hz) for aircraft systems during ground conditions. Here the main engines are off and APU provides electricity power for an aircraft. Another utilization of APU is in emergency conditions, when one or two main electrical generators are lost. A fuel cell is a system that combines hydrogen and oxygen as a fuel to produce electricity, heat, and water [3]. The APU will be replaced by a Fuel Cell Auxiliary Power Unit (FCAPU) system to reduce pollution. Fuel cells are an energy aircraft manufacturer's dream: an efficient, combustion-less and pollution-free power source. Fuel cells are an alternative power source to provide the electric power for the more electric aircraft [4-5]. Unlike the APU, the FCAPU would be more efficient. The FCAPU not only has no exhaust, but also it has warm air and pure water, both of which could be used onboard the aircraft. So far most studies have focused on using fuel cells as a battery in aircraft. Few studies have been done on examining to replace APUs with fuel cells [6-8].

Generally, two kinds of fuel cells has been used as follows:

- Low temperature Polymer Electrolyte Membrane Fuel Cell (PEMFCs)
- High temperature Solid Oxide Fuel Cell (SOFCs)

Both of them seem to be conceivable to enter the aviation markets [9]. However, in this paper, it is shown that SOFC has much higher efficiencies and thus potential to replace conventional APU. The SOFC has a solid oxide electrolyte. Benefits of this include stability, low emissions, high efficiency, fuel flexibility and low cost [12]. The operating temperature is among 500 and 1,000 °C, which leads longer start-up. However, makes this suitable candidate for some application in aircraft such as APU systems [12].

2. Integration of fuel cell to electrical power system

The electrical power generation of J150+ contains:

- Two engine-driven alternating current generators with nominal power 90kVA

- An auxiliary power unit (APU) alternating current generator with nominal power 90kVA
- An emergency generator with nominal power 5kVA that spontaneously outspreaded in case of main generators loss

In normal configuration, both Main AC Buses are split and each engine-driven generator supplies it's associated. Main AC Bus by its Generator Line Contactor (GLC) and Vital AC Bus (VAB) is normally powered from Main AC Bus by a contactor. DC Battery Bus and the Vital DC Bus (VDB) are normally powered by the transformer rectifier unit (TRU). Two batteries are joined to the DC Battery Bus (DBB) by the Battery Charge Limiter (BCL).

In case of Loss of one or two main electrical generators (IDG1 & 2), The APU would now power both sides of the electrical system. In Fig. 1, the conventional APU is replaced by the proposed FCAPU. The proposed FCAPU directly produces DC electrical power and the power converter is used to provide power to 115VAC Buses.

Also during emergency condition, Fuel cells are not capable to supply the power demanded since they have a very slow response. The FCAPU like main electric power supplier can locate in the center of the aircraft; this makes the distances to major load centers are minimized. Also the anti-ice systems on the wings can use heat from the fuel cell exhaust as shown in Fig. 2.

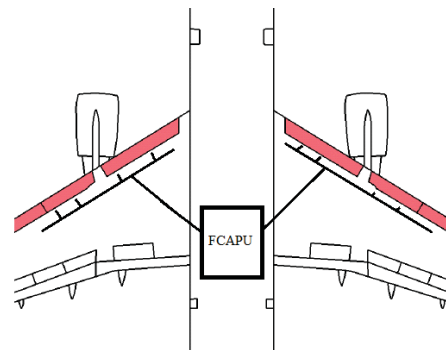

Fig. 2. Application of heat from the cell exhaust to anti-ice systems

3. Proposed FCAPU structure

The proposed FCAPU includes two fuel cell stacks, a DC/DC boost converter, DC/AC converter, multiple controllers and an energy storage system. Since fuel cell has a very slow response, the energy storage system will provide instant power [10].

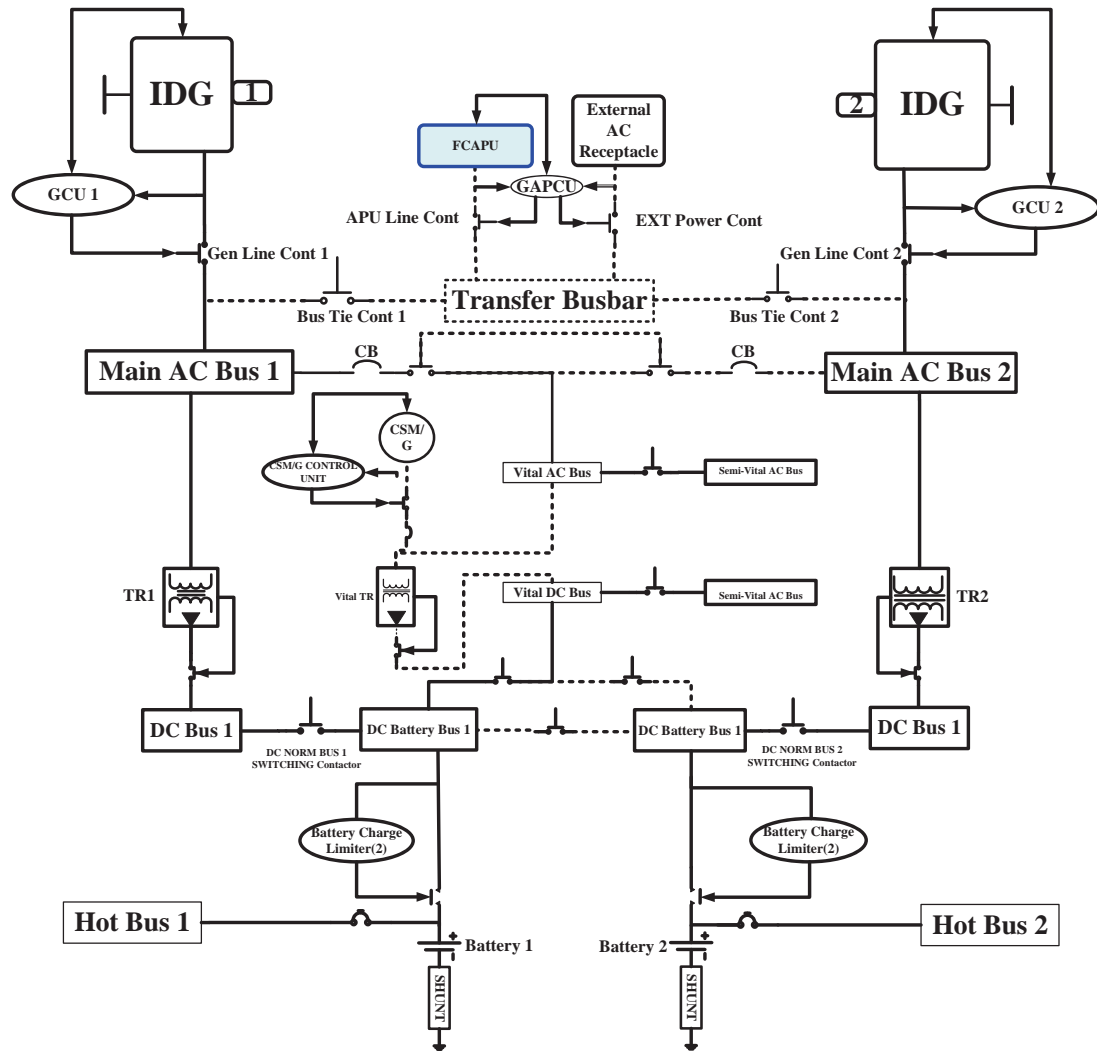

Fig. 1. Single line diagram of the restructured distribution network of the j150+ aircraft

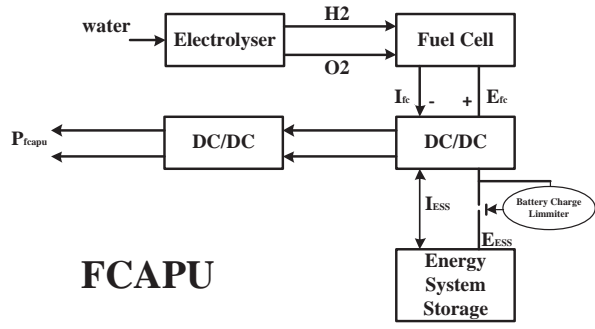
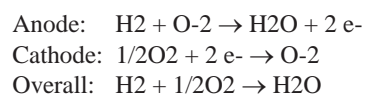

Fig. 3 The proposed FCAPU structure

3.1. Fuel cell model

SOFCS are a category of fuel cells determined because of utilization of a solid oxide material as an electrolyte. SOFCs apply a solid oxide electrolyte to conduct negative oxygen ions travel from positive side

(cathode) to the negative side (anode) as shown in Fig. 4. The electrochemical oxidation of the carbon or hydrogen monoxide with oxygen ions therefore happens on the negative side. The fuel reacts with oxygen to produce electricity. The SOFC reactions are:



Per cell voltage is 0.7~0.85 V and can be calculated using equation (1):

$$V = E_0 - iR_{\omega} - \eta_{cathode} - \eta_{anode} \quad (1)$$

where,
 E_0 : Nernst potential
 R_{ω} : Thevenin equivalent

$\eta_{cathode}$ and η_{anode} :account for the remaining difference between the actual cell voltage and the Nernst potential [11].

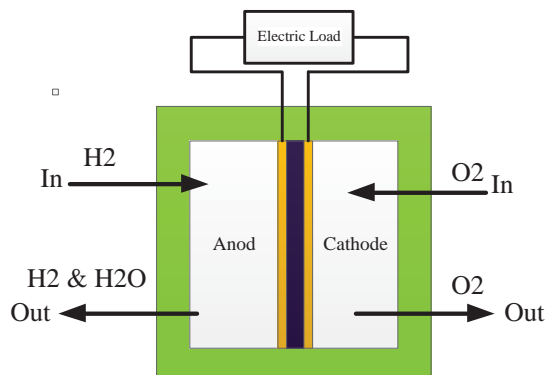

Fig.4. Diagram for SOFC

As mentioned, fuel cells generate small electrical voltages, to deliver the demanded energy; they combined in series and in parallel to higher voltage and current levels, respectively. Such as a design is named a “stack”. The stack frame intended this work is like to reference [12] with a little changes. In [12], the FC design is based on the Delphi Gen4 stack; Power density at 0.825V/cell in the active area ($508\text{cm}^2/\text{cell}$) of the cell is estimated to be 0.76 watt/cm². The FCAPU comprised two shunt stacks. Each stack comprises 97 cells (total of 194 cells) in order to prepare $97 \times 0.825 \approx 80\text{Volt}$ and the total power for two stacks is:

$$(194\text{cells}) \times \left(\frac{508\text{cm}^2}{\text{cell}}\right) \times \left(\frac{0.76\text{W}}{\text{cm}^2}\right) = 80 \text{ kW} \quad (2)$$

Table I lists the SOFC characteristics used in this paper.

table. 1.

SOFC characteristics

Operating Temp. (°C)	800-1,000
Electrical Efficiency	44%-50%
Power Density at 0.825V/Cell	0.76 watt/cm ²
Active Area	($508\text{cm}^2/\text{cell}$)

A. Electrolyzer Model

In this paper, oxygen flow rate and fuel control at desired values has been proposed in [10]. Electrolyser operates in four main conditions:

- In normal configuration
- In case of loss of one main electrical generators:
- In this condition one or two generators is running due to V_{AB} is supplied and a portion of its energy is traveled to the electrolyser to produce oxygen and hydrogen for the utilization in the other mode.
- Aircraft start-up or in case of loss of two main electrical generators

The reserved oxygen and hydrogen are traveled to Fuel Cell in order to produce electrical energy for aircraft start-up as shown in Fig. 5.

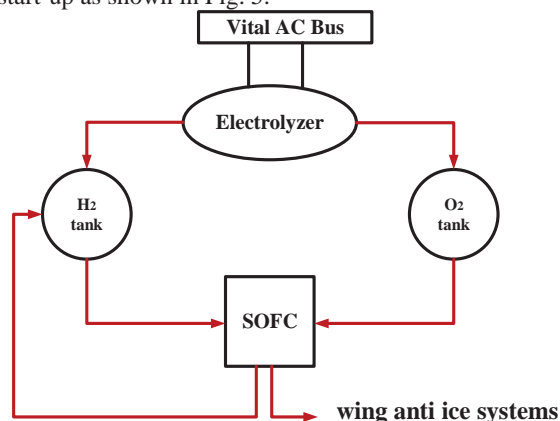

Fig. 5. Configuration of SOFC with electrolyzer, O2 and H2 tanks

3.2. DC/DC boost converter Model

The DC/DC boost converter performs the function voltage regulation. This is a power converter that rises up the input 80V voltage to generate a superior 115V output voltage. The DC/DC boost converter and its control structure are illustrated in Fig. 5. DC/DC boost converter comprises:

- One switch, (a MOSFET or IGBT (SW1))
- Diode (D)
- Inductor (L)
- Capacitor (COUT).

The function of the DC/DC boost converter is a switch that control an inductor. The inductor alternatively stores energy with connecting to source voltage and discharging this energy into the load [13].

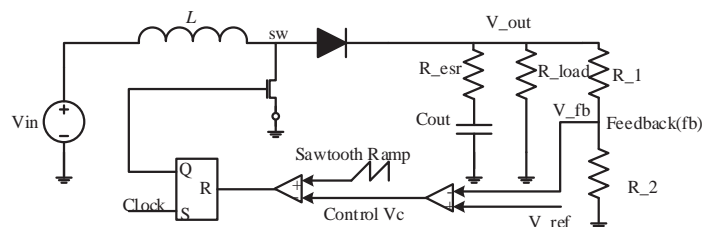

Fig. 6. DC/DC boost converter and control structure

PWM technique is required for regulating Duty Cycle (D) to get the demanded voltage output. The feedback voltage is compared to the reference voltage to make an error signal by the trans conductance of the error amplifier. After passing the compensation impedance, the error signal was converter to control voltage, V_c , and was connected to the PWM. Then V_c is compared with a sawtooth ramp. Whenever the output voltage alters, the V_c alters and due to the D of the power switch to alert. This alter of D regulate the output voltage to decrease error to zero. The output and input voltage ratio is controlled by the D according to the (3).

$$V_{out} = \left(\frac{1}{1-D} \right) V_{in} \quad (3)$$

3.4. Inverter Model

Fig. 7 shows the structure of a three-phase PWM inverter connected to DC/DC boost converter output and aircraft's transfer bus. The inverter comprises [14-18]:

- A three-phase bridge.
- A three-phase filter to eliminate the distortion in the voltage waveform produced at the ac side of the inverter.
- line inductors to restrict the rate of change of the current flowing through the ac side of the inverter
- current and voltage sensors
- A current control loop

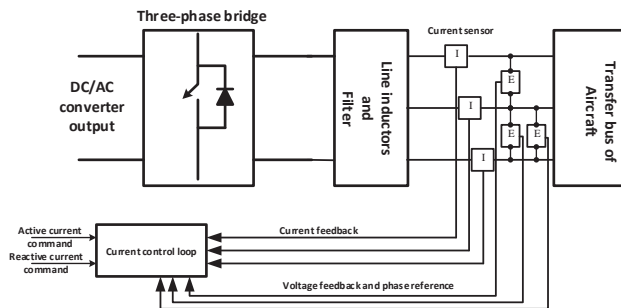

Fig.7. Structure of a three-phase PWM inverter

The three-phase inverter is connected to DC/DC boost converter output and aircraft's transfer bus.

4. Simulation results

The performance of the proposed FCAPU is simulated in MATLAB/SIMULINK. A 3-phase inverter is used after DC-DC converter to connect it to main AC bus of the j150+ aircraft.

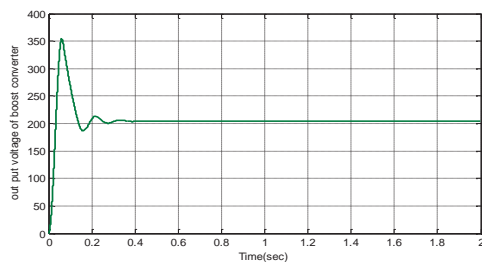

Fig.8 . Output voltage of DC-DC converter without implementing filters

Fig 8-10 show DC-DC converter's output voltage, applied to the inverter. Moreover, Figs. 9 and 10 shows the 3-phase for worse and best THD circumstance. The proposed FCAPU could generate the Oxygen usage for aircraft. Simulation results successfully show ability of the proposed FCAPU in twin engine aircraft application.

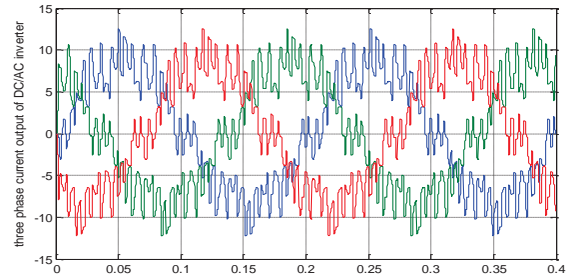

Fig. 9 . Inverter's output current in worst case THD

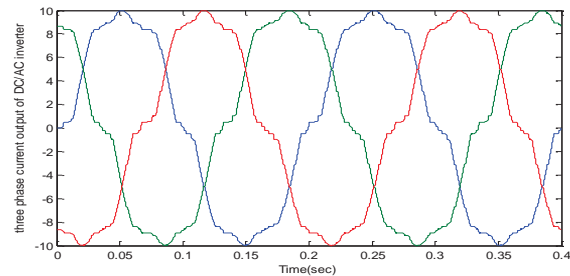

Fig.10 . Inverter's output current in best case THD

5. Conclusion

Potential benefits of utilization fuel cells as an electrical power source include reduction in aircraft engine size, efficient energy conversion, and low gas emissions. The most expectancy type of fuel cells for commercial aircraft is SOFC. Several technical challenges exist to incorporating fuel cells as power sources in J150+ aircraft. Challenges for fuel cell development include continued development of electrical actuators, efficient power control systems, and high power electronics. Each of these is needed to enable the MEA architecture necessary to fully utilize fuel-cell-generated electricity.

Reference

- [1] Brombach, J.; Lucken, A.; Schulz, D., "Extended power delivery with fuel cell systems," Electrical Systems for Aircraft, Railway and Ship Propulsion (ESARS), 2010, vol., no., pp.1-6, 19-21 Oct. 2010.
- [2] Kar, Rahul. "Dynamics of implementation of mitigating measures to reduce CO₂ emissions from commercial aviation." PhD diss., Massachusetts Institute of Technology, 2010.
- [3] Kanhu Charan Bhuyan, Sumit Kumar Sao, and Kamalakanta Mahapatra, "An FPGA Based Controller for a SOFC DC-DC Power System," Advances in Power Electronics, vol. 2013, Article ID 345646, 12 pages, 2013.
- [4] Rajashekara, K., Grieve, J., and Daggett, D., "Hybrid Fuel Cell Power in Aircraft: A feasibility study for onboard power generation using a combination of solid oxide fuel cells and gas turbines," IEEE Industry Application Magazine, vol. 14, no. 3, pp. 54-60, 2008.
- [5] Lucken, A.; Brombach, J.; Schulz, D., "Design and protection of a high voltage DC onboard grid with integrated fuel cell system on more electric aircraft,"



Electrical Systems for Aircraft, Railway and Ship Propulsion (ESARS), 2010 , vol., no., pp.1,6, 19-21 Oct. 2010.

- [6] Adamson, 2005, K.A., Fuel Cell Planes
- [7] Ganesh, D.; Gowrishankar, G., "Effect of nano-fuel additive on emission reduction in a biodiesel fuelled CI engine," 2011 International Conference on Electrical and Control Engineering (ICECE), vol., no., pp.3453-3459, 16-18 Sept. 2011.
- [8] Eid, A.; El-Kishky, H.; Abdel-Salam, M.; El-Mohandes, T., "Modeling and characterization of an aircraft electric power system with a fuel cell-equipped APU connected at HVDC bus," 2010 IEEE International Power Modulator and High Voltage Conference (IPMHVC), vol., no., pp.639-642, 23-27 May 2010.
- [9] K. Munoz-Ramos, J. W. Pratt, A. A. Akhil, B. L. Schenkman, L. E. Klebanoff and D. B. Curgus, "Electrical analysis of Proton Exchange Membrane fuel cells for electrical power generation on-board commercial airplanes," 2012 IEEE Transportation Electrification Conference and Expo (ITEC), Dearborn, MI, 2012, pp. 1-6.
- [10] Hamid Radmanesh, Seyed Saeid Heidari Yazdi, G. B. Gharehpetian, and S. H. Fathi, "Modelling and Simulation of Fuel Cell Dynamics for Electrical Energy Usage of Hercules Airplanes," The Scientific World Journal, vol. 2014, Article ID 593121, 10 pages, 2014.
- [11] Hai-Bo Huo, Xin-Jian Zhu, Guang-Yi Cao, Nonlinear modeling of a SOFC stack based on a least squares support vector machine, Journal of Power Sources, vol. 162, no. 2, pp. 1220-1225, 22 November 2006.
- [12] GA Whyatt, LA Chick, "Electrical Generation for More-Electric Aircraft using Solid Oxide Fuel Cells", U.S. Department of Energy under Contract, 2012.
- [13] Roshan, Y.M.; Moallem, M., "Control of Non-minimum Phase Load Current in a Boost Converter Using Output Redefinition," IEEE Transactions on Power Electronics, vol.29, no.9, pp.5054-5062, Sept. 2014.
- [14] Juinne-Ching Liao; Sheng-Nian Yeh, "A novel instantaneous power control strategy and analytic model for integrated rectifier/inverter systems," IEEE Transactions on Power Electronics, vol.15, no.6, pp.996-1006, Nov 2000.
- [15] H. Matsumori, T. Shimizu, K. Takano and H. Ishii, "Evaluation of Iron Loss of AC Filter Inductor Used in Three-Phase PWM Inverters Based on an Iron Loss Analyzer," in IEEE Transactions on Power Electronics, vol. 31, no. 4, pp. 3080-3095, April 2016.
- [16] D. Q. Dang, Y. S. Choi, H. H. Choi and J. W. Jung, "Experimental Validation of a Fuzzy Adaptive Voltage Controller for Three-Phase PWM Inverter of a Standalone DG Unit," in IEEE Transactions on Industrial Informatics, vol. 11, no. 3, pp. 632-641, June 2015.
- [17] Wenzhi Zhou and Dan Sun, "Adaptive PWM for four-switch three-phase inverter," in Electronics Letters, vol. 51, no. 21, pp. 1690-1692, 10 8 2015.
- [18] Xiang Wu, Guojun Tan, Zongbin Ye, Yi Liu and Shizhou Xu, "Optimized Common-Mode Voltage Reduction PWM for Three-Phase Voltage-Source Inverters," in IEEE Transactions on Power Electronics, vol. 31, no. 4, pp. 2959-2969, April 2016.