

# Design and Simulation of a Clamped-Clamped Micromechanical Beam AM Frequency Mixer-Filter

Atefeh Gholipour<sup>1</sup> Khalil Mafinezhad<sup>2</sup>

<sup>1</sup>Ph. D. Student, Department of Electrical Engineering, Ferdowsi university of Mashhad, Mashhad, Iran

[Atefeh.gholipour@mail.um.ac.ir](mailto:Atefeh.gholipour@mail.um.ac.ir)

<sup>2</sup>Professor, Department of Electrical Engineering, Ferdowsi university of Mashhad, Mashhad, Iran and Sadjad institute of higher education

[khmafinezhad@gmail.com](mailto:khmafinezhad@gmail.com)

## Abstract :

In the last decade Micromechanical components for communication applications has been fabricated via IC-compatible MEMS technologies. In fact, its most important impact is not at the component level, but rather at the system level, by offering alternative transceiver architectures that reduce power consumption and enhance performance. In this paper a mixer-filter for AM frequency receiver with MEMS based on one clamped-clamped beam resonator is presented. Mixing and filtering functions are achieved by one component. By combining mixer and filter in one component, in addition to size reduction for portable communication devices, power consumption is also reduced. Mixer-filter can down-convert the RF frequency of 1.655MHz to IF frequency of 455 kHz with a bandwidth of 8 kHz by local oscillator frequency of 2.11 MHz. This technique can be used for much higher RF frequencies. The unloaded Q of this device is 7714 and it could be used as narrow band filter, this design has high linearity too with IIP3 13.6dBm. Above all, by integrating this mixer filter with the rest of the circuit it is more economical than other conventional receivers.

**Keywords:** Micromechanical MEMS, resonator, quality factor, IC compatible fabrication, mechanical coupling, Clamped-Clamped beam

---

**Submission date:** 29 , April , 2014

**Conditionally Acceptance date:** 13, June, 2015

**Acceptance date:** 22, Dec., 2015

**Corresponding author:** Atefeh Gholipour

**Corresponding author's address:** Ferdowsi University of Mashhad (FUM), Azadi Sq., Mashhad, Khorasan Razavi, Iran



## 1. Introduction

Mechanical resonators like quartz crystals and SAW resonators are widely used in communication circuits for their high-Q, high selectivity and enough stability against temperature. These components are off-chip that interfaces with signal processing circuitry at the board level and this causes an important bottleneck to miniaturization and performance of super heterodyne transceivers. Micromachining technologies make possible high-Q on-chip micromechanical resonators [1]. IC compatibility, size reduction and power-savings are reasons for replacing SAW and crystals by equivalent MEMS devices. Using one component for mixing and IF filtering addition to size reduction for portable communication systems, power consumption decreased considerably due of absence of matching problem between mixer output and subsequent filters. Furthermore, impedance mismatches between the mixer output and filter input can contribute additional insertion loss in receive and transmit paths [2].

MEMs resonator has designed in various shape respect to their operating frequency. In sensor application the resonate frequency is usually below 100 KHz, thus reach to high sensitive device use techniques that extend linearity and displacement amplitude, such as interdigitated comb-capacitive transducers and folded-beam suspensions [3]. Clamped-clamped resonators usually in low and medium frequency, for higher frequency bulk resonators in circle and rectangular shapes are used [4,5].

Medium frequency receivers are used in AM broadcasting and maritime mobile service. Mixer-filter with 27MHz and 37MHz IF frequency using two clamped-clamped beam [6,7] and CMOS-MEMS mixer-filter in 433KHz and 6.4MHz IF frequency have been demonstrated [8,9]. These structures used two clamped-clamped beams with a narrowband coupling beam which is increases the probability of failure.

In this paper mixer-filter in 455 KHz frequency with one clamped-clamped beam is proposed and discusses about its design and characteristic. Using one beam has some advantage such as eliminating the failure caused by coupling beam as well as reduction in occupied area. This technique can be used for much higher frequencies by improving RF characteristics of MEMS switch [10-14] although it limited by minimum and maximum accepted length of beam.

The paper is organized as follows. The proposed mixer-filter structure is presented in Section 2. Section 3 gives a brief introduction of micromechanical resonators and their formulation. The equivalent mechanical and electrical circuit of resonators presented in section 4 and 5 respectively. Section 6 gives the design procedure to reach mentioned operating frequency. The designed Mixer-Filter characteristic is presented in section 7. Section 8 concludes this paper.

## 2. Mixer-Filter Structure and Operation

Proposed mixer-filter is designed by one clamped-clamped beam as shown in Fig. 1. Excitations configuration are also shown in this figure.  $L_r$  and  $h_r$  are the length and height of resonator,  $W_e$  is the width of electrode,  $d_0$  is the gap between resonator and electrodes and  $W_r$  is the resonator's width which is not shown in figure.

The key to mixing in this device is its capacitive electromechanical transducer, which converts electrical energy (i.e., voltage) to mechanical energy (i.e., force) via a square law transfer function. This force can be expressed as [3]

$$F_t = \frac{1}{2}(V_{dc} - v_{LO} + v_{RF})^2 (\partial C_1 / \partial x) = \dots - v_{LO} v_{RF} \frac{\partial C_1}{\partial x} + \dots \quad (1)$$

$$= \dots - \frac{1}{2} |v_{LO}| |v_{RF}| \frac{\partial C_1}{\partial x} \cos(\omega_{LO} - \omega_{RF})t + \dots$$

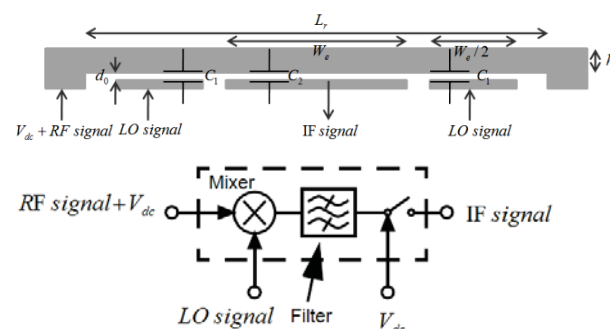

Fig. 1. Schematic diagram of the mechanical mixer-filter and equivalent block diagram

where  $C_1$  is the electrode to beam capacitor. Thanks to this nonlinear relation the IF frequency ( $\omega_{IF} = \omega_{LO} - \omega_{RF}$ ) produce; if resonant frequency of beam set to IF frequency it operates as a filter which passes IF frequency and eliminates other frequencies in equation 1. Beam vibration works as time variable capacitor, with DC voltage applied to this capacitor, current is generated in output electrode. Magnitude of this current is calculated by following equation.

$$i_{x2} = V_{dc} \frac{\partial C_2}{\partial x} \frac{\partial x}{\partial t} \quad (2)$$

which  $x$  is vertical displacement,  $\partial C_2 / \partial x$  is electrode to beam capacitor variation at the output transducer. The current  $i_{x2}$  is then directed to output resistor which is proper termination impedance. Output voltage then buffered, amplified and used after that.

## 3. Micromechanical Resonators

Center frequency of mechanical resonator is equal to the mixer-filter's output frequency. The selected microresonator design not only must be able to achieve

the needed frequency but also must do so with adequate linearity and tunability, and with sufficient Q. Resonance frequency of a beam is calculated by  $f_0 = (1/2\pi)\sqrt{k_r/m_r}$  [15]. The resonance frequency of a clamped-clamped beam depends on geometry, structural material properties, stress, the magnitude of the applied dc-bias voltage VDC, and surface topography. Accounting for these while neglecting finite width effects, an expression for resonance frequency can be written as

$$f_0 = f_{nom}[1 - g(d, V_{dc})]^{1/2} = \frac{1}{2\pi} \sqrt{\frac{k_m - k_e}{m_r}} \quad (3)$$

$$f_{nom} = 1.03\kappa \sqrt{\frac{E}{\rho}} \frac{h}{L_r^2}$$

where E and  $\rho$  are the Young's modulus and density of the structural material.  $h$  and  $L_r$  are thickness and length of beam as specified in Fig. 1.  $f_{nom}$  is the nominal mechanical resonance frequency of the resonator if there were no electrodes or applied voltages; the function  $g$  models the effect of an electrical spring stiffness  $k_e$  that appears when electrodes and voltages are introduced and that subtracts from the mechanical stiffness  $k_m$ ; and  $\kappa$  is a scaling factor that models the effects of surface which is predictable using finite element analysis.

#### 4. Equivalent Mechanical Circuit

For proper design, it's easier to define an equivalent lumped-parameter mass-spring-damper mechanical circuit for resonator which shown in Fig. 2.

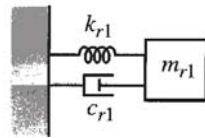

Fig. 2. Equivalent Mechanical Circuit

Equivalent circuit's values are obtained by following equations [16].

$$m_r(y) = \frac{KE_{tot}}{(1/2)(v(y))^2} = \frac{\rho W_r h_r \int_0^{L_r} [X_{mode}(y')]^2 (dy')}{[X_{mode}(y')]^2} \quad (4)$$

$$X_{mode}(y') = \zeta(\cos ky - \cosh ky) + (\sin ky - \sinh ky) \quad (5)$$

$K = 4.730/L_r$  and  $\zeta = -1.01781$  for the fundamental mode,  $KE_{tot}$  is the peak kinetic energy in the system,  $v(y)$  is the velocity at location  $y$ , and dimensional parameters are given in Fig. 1.  $X_{mode}$  is the shape function which is given in (5). The equivalent spring stiffness follows readily from resonance frequency equation and (4) and is given by

$$k_r = \omega_0^2 m_r(y) \quad (6)$$

Finally the damping factor is given by

$$c_r(y) = \frac{\sqrt{k_m(y)m_r(y)}}{Q_{nom}} = \frac{\omega_{nom}m_r(y)}{Q_{nom}} = \frac{k_m(y)}{\omega_{nom}Q_{nom}} \quad (7)$$

$$k_m(y) = \omega_{nom}^2 m_r(y) \quad (8)$$

$k_m$  is the mechanical stiffness of the resonator alone, without the influence of applied voltages and electrodes and  $Q_{nom}$  is the quality factor of the resonator under the same conditions.

#### 5. Electrical Equivalent Circuit

Conveniently model is needed to analyses and simulates the impedance behavior of this mechanical resonator in an electromechanical circuit.

Fig. 3. presents the equivalent electrical circuit, in which transformers model both electrical and mechanical couplings to and from the resonator, which itself is modeled by a core LCR circuit—the electrical analogy to a mass-spring-damper system—with element values corresponding to actual values of mass, stiffness, and damping as given by (4)–(7). In this circuit, the current electromechanical analogy is utilized and summarized in table.1.

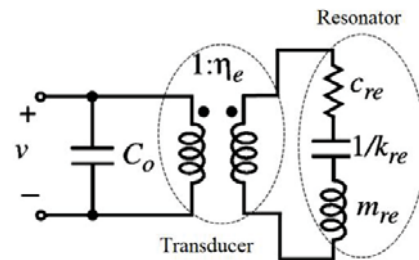

Fig. 3. Equivalent electrical circuit

table. 1. Mechanical-to-electrical correspondence

Mechanical variable	Electrical variable
Resistance, R	Damping, c
Capacitance, C	Stiffness <sup>-1</sup> , k <sup>-1</sup>
Inductance, L	Mass, m
Voltage, V	Force, f
Current, I	Velocity, v

When looking into the electrode port of the equivalent resonator circuit of Fig. 3, a transformed LCR circuit is seen, with element values given by

$$C_{nx} = \frac{\eta_e^2}{k_{re}}, \quad R_{nx} = \frac{\sqrt{k_{re}m_{re}}}{Q\eta_e^2}, \quad L_{nx} = \frac{m_{re}}{\eta_e^2} \quad (9)$$

$$\eta_e^2 = V_{dc} \frac{\partial C}{\partial x}, \quad \frac{\partial C}{\partial x} = \frac{\epsilon_0 W_r W_e}{d_0^2}$$

Where  $W_r$  is beam width and the subscript denotes the electrode location at the very center of the resonator beam( $y=L_r/2$ ) [16].

#### 6. Circuit Design Using Clamped-Clamped Beam Micromechanical Resonator

In this section, resonator design is described for AM frequency. Notice to this point, the motional resistance in resonator output must be as low as possible to have a



convenient impedance matching. To decrease the impedance, DC voltage must be increased which limited by maximum allowable beam pull in voltage or technology. The pull in voltage calculated using

$$V_p = \sqrt{\frac{8k}{27\epsilon_0 W_r W_e}} d_0^3 \quad (10)$$

The other ways are gap reduction and electrode area enhancement. Minimum gap determined by fabrication technology and reliability. Increase in electrode area is limited by resonator length which determine by resonant frequency.

### 6.1. Resonant frequency simulation

Calculated resonator dimensions to reach required specification and material properties are listed in table. 2.

By using calculated values, simulations are done using COMSOL for clamped-clamped beam. In Fig. 4 the first resonance frequency is shown.

table. 2. Material property and design parameter's value

Parameter	Value
$L_r$ (resonator length)	187 $\mu$ m
$W_r$ (resonator width)	40 $\mu$ m
$h_r$ (resonator depth)	2 $\mu$ m
$W_e$ (electrode width)	80 $\mu$ m
$d_0$ (gap)	1 $\mu$ m
Material properties	
E (Young's modulus for poly-si)	160Gpa
$\rho$ (Density of poly-si)	2320 kgm <sup>3</sup>
$\nu$ (Poisson's ratio)	0.22
$\alpha_T$ (Thermal expansion coefficient)	2.6 $\times 10^{-6}$ K <sup>-1</sup>
$C_T$ (Thermal conductivity)	90 Wm <sup>-1</sup> K <sup>-1</sup>
$C_v$ (Specific heat)	1.63 $\times 10^6$ JK <sup>-1</sup> m <sup>-3</sup>

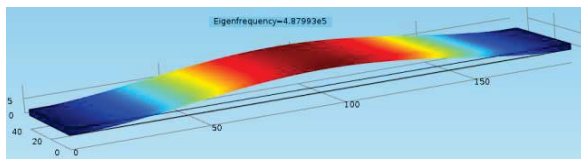

Fig. 4. First mode of resonator (mode1: 490 KHz)

Other resonant frequencies for higher modes are given in table. 3.

table. 3. Material property and design parameter's value

Mode number	Value
Mode 2	1.35 MHz
Mode 3	2.64 MHz
Mode 4	4.36 MHz
Mode 5	6.5 MHz

We use first mode here. As shown in equations, resonant frequency varies with DC voltage. In Fig. 5 the variations of first mode frequency with apply voltage is shown. The value of resonant frequency in 25V reaches to 455 KHz.

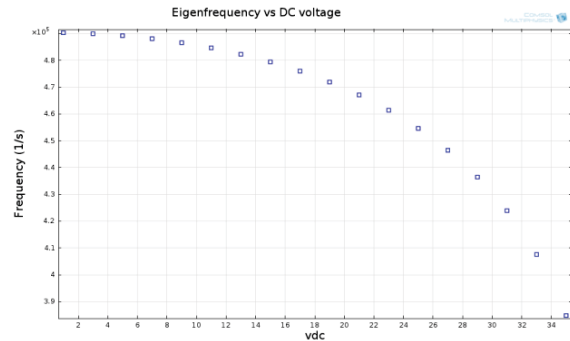

Fig. 5. Variations of first mode frequency with apply voltage

To ensure the collapse doesn't occur for beam, pull in voltage is calculated which is equal to 38V. In Fig. 6 effect of DC voltage on gap is illustrated.

To find the values of the parameters of the circuit's model, first the quality factor of resonator must be calculated.

### 6.2. Quality Factor Calculation

Energy dissipation in resonators during vibrations is depended on intrinsic structure parameters and environment condition which are cause damping. Many dissipation mechanisms exist in micromechanical resonators which are mentioned below.

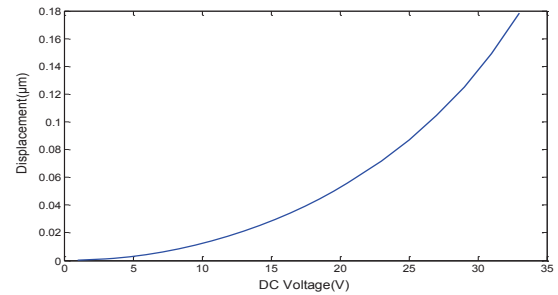

(a)

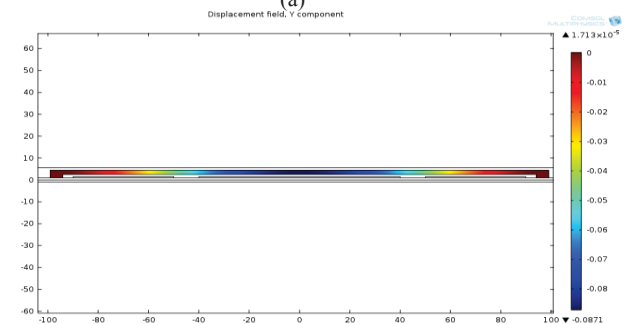

(b)

Fig. 6. (a) Vertical displacement versus voltage (b) displacement in 25V

### 6.2.1. Structural or Thermoelastic Damping

Beam bending during vibration, create heat gradient in structure. This gradient cause heat transfer from heater part to cooler part and this transformation causes energy loss. Quality factor due to this mechanism for a homogeneous structure is expressed as [17].

$$Q_{TED}^{-1} = \frac{E\alpha_T^2 T_0}{C_v} \frac{\omega\tau}{1+(\omega\tau)^2}, \tau = \frac{C_v W_r^2}{C_T \pi^2} \quad (11)$$

Where  $C_v$ ,  $C_T$ ,  $\alpha_T$  and  $\omega$  are specific heat, thermal conductivity, thermal expansion coefficient and resonant frequency respectively and for polysilicon these constants are listed in table. 2.

### 6.2.2. Air Damping

Air damping is an important loss mechanism in micro scale structure. When the structure moved, pulling out the air molecules from air gap cause force air damping. To define quality factor of this loss following equation can be used [18].

$$Q_{air} = (2\pi)^{3/2} \rho h_r \omega \frac{d_0}{2L_r + 2W_r} \sqrt{\frac{RT}{M_{mol}}} \frac{1}{P} \quad (12)$$

with  $R = 8.314 \text{ m}^2 \text{NK}^{-1} \text{mol}^{-1}$  as the universal gas constant and  $M_{mol}$  is the molar weight of gas which defines 28.96 g/mol for air.

### 6.2.3. Support Loss Damping

Part of energy given to the vibrating structure is lost in fixed anchors. The loss phenomena can be described by the wave propagation theory in the material. The supporting damping equation for a clamped-clamped beam resonator is written as [19]

$$Q_{support} = \varphi_n \left( \frac{L_r}{h_r} \right)^3 \quad (13)$$

Where  $\varphi_n$  is the support loss coefficient of the resonator and for each resonance modes is different (for first mode it's equal to 0.638).

### 6.2.4. Surface Loss Damping

Contamination at the resonator surface can also cause degradation of the quality factor. Equation to model this mechanism is illustrated here [19].

$$Q_{surface} = \frac{W_r h_r}{3W_r + h_r} \frac{E}{2\delta E_{ds}} \quad (14)$$

Where  $\delta E_{ds}$  referred to surface Young's modulus and according to the experimental result it calculated 1.38. Finally, the total quality factor can be found by equation (14)

$$\frac{1}{Q} = \sum_i \frac{1}{Q_i} = \frac{1}{Q_{TED}} + \frac{1}{Q_{surface}} + \frac{1}{Q_{air}} + \frac{1}{Q_{support}} \quad (15)$$

Calculated quality factors and total Q are presented in TABLE 4. Pressure of ambient assumed 40mTorr.

Now with parameter found by simulation and calculated Q, mechanical and electrical circuit element can be calculated and listed in table 5.

table. 4. Calculated quality factor of each loss mechanism and total Q

Total Q	$Q_{support}$	$Q_{air}$	$Q_{surface}$	$Q_{TED}$
7714	521501	169563	38013	10469

table. 5. Micromechanical resonator characteristic

Parameter	Value
$f_{nom}$	490 KHz
$f_r$	455 KHz
$m_r$	$3.47 \times 10^{-11}$ Kg
$K_r$	283 N/m
$K_m$	329 N/m
$K_e$	46 N/m
$C_{01}$	$1.36 \times 10^{-14}$ F
$C_{02}$	$2.72 \times 10^{-14}$ F
$l_x$	$3.47 \times 10^{-11}$ H
$c_x$	$3.5 \times 10^{-3}$ F
$r_x$	$8.12 \times 10^{-8}$ $\Omega$
$\eta_i$	$3.4 \times 10^{-7}$
$\eta_o$	$6.8 \times 10^{-7}$

## 7. Proposed Mixer-Filter Characteristic

To find the mixer-filter characteristic we use equivalent electrical circuit. With element listed in table 5 the equivalent circuit found and illustrated in Fig. 7.

Port 1 is input electrode, port 2 is output electrode and port 3 is common port which is ground. The capacitance between port 3 and ground due to sio2 isolation layer on substrate is not shown. To find mixer-filter characteristic we assume the frequency of RF and LO signal are 1.655 MHz and 2.11 MHz, respectively.

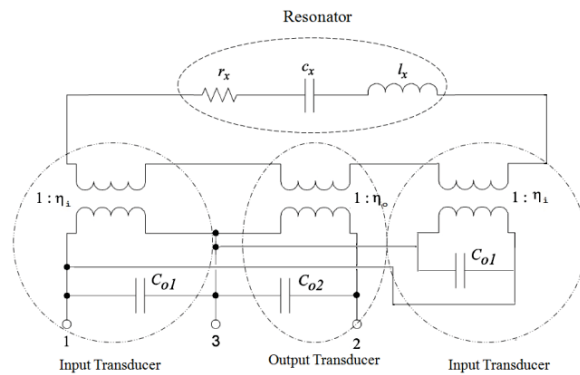

### 7.1. Bandwidth and insertion loss

Simulated frequency characteristic of equivalent electrical circuit is shown in Fig. 8 using ADS.



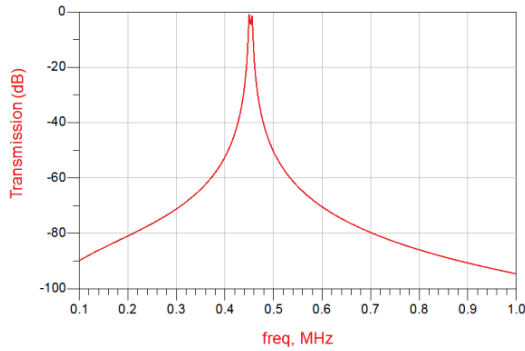

Fig. 8. Frequency characteristic

As seen in Fig. 8, bandwidth and insertion loss of filter output is 8 KHz and 0.8dB.

## 7.2. Linearity

Analytical formulations of the third-order input intercept point (IIP3) for a clamed-clamped beam are presented in [20] and it found by following equations

$$V_{IIP3} = \left\{ \frac{1}{4} \frac{\epsilon_0 A_0}{d_0^3} \frac{1}{K_{eff}} (2\Theta_1 + \Theta_2^*) \right. \\ \left. + \frac{3}{4} \frac{(\epsilon_0 A_0)^2}{d_0^6} \frac{V_{DC}^2}{K_{eff}^2} \Theta_1 (\Theta_1 + 2\Theta_2^*) \right. \\ \left. + \frac{3}{2} \frac{(\epsilon_0 A_0)^3}{d_0^9} \frac{V_{DC}^4}{K_{eff}^3} \Theta_1^2 \Theta_2^* \right\}^{-1/2} \quad (16)$$

$$\Theta(\omega) = \frac{1}{1 - (\omega/\omega_0)^2 + j\omega/(Q\omega_0)} \quad (17)$$

Although  $V_{IIP3}$  is widely used for expressing IIP3, some applications may prefer that IIP3 be expressed as a power instead. The IIP3 power  $P_{IIP3}$  can be determined from  $V_{IIP3}$  via the expression

$$P_{IIP3} = 10 \log \left( \frac{V_{IIP3}^2}{2(R_x + R_T)} \right) \quad (18)$$

Where  $R_x$  is motional resistor and  $R_T$  is termination resistor. To put the design value in above equation  $P_{IIP3}$  for designed micromechanical mixer-filter find 13.6 dBm and this result shows good linearity for circuit.

## 7.3. Isolation

In this section the isolation between RF, LO and IF port is presented. They defined by the effect of capacitor between related electrodes. Isolation can be found by simulation of the electrical circuit. RF and LO to IF isolation found 69dB and 71dB.

## 7.4. Conversion-Insertion Gain

The conversion-insertion gain of a mixer-filter is obtained by dividing the resonant output voltage amplitude by the input RF voltage amplitude

$$G_{c-i} = \frac{|V_{out}|}{|V_{RF}|} = \frac{\epsilon_0^2 A^2 \sqrt{m}}{2d_0^4 b_{eff} \sqrt{k_{eff}} (C_0 + C_P)} V_{LO} \Delta V_{DCout} \quad (19)$$

Where  $C_P$  is parasitic and next stage input capacitor. By ignoring parasitic and next stage's input capacitor, the calculated conversion-insertion gain is 18 dB. Summary of mixer-filter characteristic is presented in table 6 and compare with [16].

table. 6. Micromechanical resonator characteristic

Parameter	our model	[15]
$f_r$	455 KHz	7.8 MHz
Filter insertion loss	0.8 dB	1.35 dB
Bandwidth	8 KHz	18 KHz
$P_{IIP3}$	13.6 dBm	NA
Conversion-Insertion Gain ( $V_{LO}=5V$ )	18 dB	NA
RF to IF isolation( $f_{RF}=1.655MHz$ )	69dB	NA
LO to IF isolation( $f_{LO}=2.11MHz$ )	71dB	NA
$d_0$	1 $\mu$ m	0.13 $\mu$ m

## 8. Conclusion

Design and simulation of a mixer-filter for AM frequency is presented by MEMS technology. The RF cut off frequency of MEMS is very high (in range of hundreds of GHz) and mechanical resonator frequency is low (up to MHz). We try to use MEMS as a down convertor mixer for converting high frequency to IF frequency application in most recent wireless system. Proposed mixer-filter with high selectivity (high Q around 7714) can down-convert the RF frequency of 1.655MHz to IF frequency of 455 kHz with a bandwidth of 8 kHz by local oscillator frequency of 2.11 MHz. MEMS based circuit exhibits high linear behavior, in this design IIP3 was calculated 13.6 dB. This proposed mixer-filter uses only one resonator for mixing and filtering, therefore, it occupy less area rather than same micromechanical mixer-filter in this frequency. Another advantage is air gap which set to 1 $\mu$ m and compare to other model with air gap around 130nm having simpler fabrication process and higher reliability. The most important benefit of MEMS based circuits is their power reduction which allows replacing them by conventional circuit in portable devices. This design is compatible with standard MEMS fabrication.

## References

- [1] C.T.-C. Nguyen, "Frequency-selective MEMS for miniaturized low-power communication devices", IEEE Trans. Microwave Theory Technol., vol. 47, no. 8, pp. 1486–1503, 1999.
- [2] W. C. Tang, T.-C. H. Nguyen, and R. T. Howe, "Laterally driven polysilicon resonant microstructures," Sensor Actuator, vol. 20, pp. 25-32, 1989.
- [3] A.-C. Wong, H. Ding, and C. T.-C. Nguyen, "Micromechanical mixer+filters," Technical Digest, IEEE International Electron Devices Meeting, San Francisco, California, Dec. 6-9, 1998, pp. 471-474.
- [4] J.R. Clark, W.-T. Hsu, M.A. Abdelmoneum, and C.T.-C. Nguyen, "High-Q UHF micromechanical radial-

- contour mode disk resonators," *J Microelectromech Syst*, vol. 14, no. 6, pp. 1298–1310, 2005.
- [5] Y. Xu, and J. E.-Y. Lee, "Single-Device and On-Chip Feedthrough Cancellation for Hybrid MEMS Resonators," *IEEE Trans. Ind. Electron.*, vol. 59, no. 12, pp. 4930-4937, 2012.
  - [6] A. C. Wong, and C. T. C. Nguyen, "Micromechanical Mixer-Filters ('Mixlers')," *J. Microelectromech. Systems*, vol. 13, pp. 100–112, 2004.
  - [7] G. Fedder, "CMOS-MEMS Resonant Mixer-Filters," in *Technical Digest of the IEEE International Electron Device Meeting*, 2005, pp. 274-277.
  - [8] F. Chen, J. Brotz, U. Arslan, C. Lo, T. Mukherjee, and G. Fedder, "CMOS-MEMS resonant RF mixer-filters," *18th IEEE International Conference on Micro Electro Mechanical Systems*, 2005. pp. 24-27.
  - [9] J. R. Clark, W.-T. Hsu, and C. T.-C. Nguyen, "High-Q VHF micromechanical contour-mode disk resonator," *Technical Digest, IEEE Int. Electron Devices Meeting*, San Francisco, California, Dec. 11-13, 2000, pp. 493-496.
  - [10] Jr, W. Weaver, S. P. Timoshenko, and D. H. Young, *Vibration Problems in Engineering*, 2th ed. New York: Wiley, 1937.
  - [11] Y. Mafinejad, A. Z. Kouzani, K. Mafinezhad, and D. Izadi, "Design and simulation of a RF MEMS shunt switch for Ka and V bands and the impact of varying its geometrical parameters," *International Midwest Symposium IEEE Circuits and Systems*, Piscataway, 2009.
  - [12] Y. Mafinejad, K. Mafinezhad, and A.Z. Kouzani, "Improving RF characteristics of MEMS capacitive shunt switches," *International Review of Modeling and Simulations (IREMOS)*, 2009.
  - [13] Y. Mafinejad, A. Kouzani, and K. Mafinezhad, "Review of low actuation voltage RF MEMS electrostatic switches based on metallic and carbon alloys," *Journal of Microelectronics, Electronic Components and Materials*, vol. 43, no. 2, pp. 85 – 96, 2013.
  - [14] H. Nabovati, K. Mafinezhad, A. Nabovati, and H. Keshmiri, "Comprehensive electromechanical analysis of MEMS variable gap capacitors," *Journal of Iranian Association of Electrical and Electronics Engineers*, vol. 4, no. 2, 2007.
  - [15] Y. Mafinejad, M. Zarghami, and A.Z Kouzani, "Design and simulation of high isolation RF MEMS shunt capacitor switch for C-K band," *ICEE*, Mashad, Iran, 2013.
  - [16] F. D. Bannon, J. R. Clark, and C. T.-C. Nguyen, "High-Q HF Microelectromechanical Filters," *IEEE J. Solid-State Circuits*, vol. 35, no. 4, pp. 512-526, 2000.
  - [17] A. Duwel, RN Candler, TW. Kenny, and M. Varghese, "Engineering MEMS resonators with low thermoelastic damping," *J. Microelectromech. Syst.*, vol. 15, no. 6, 2006.
  - [18] MH. Bao, and H. Yang, "Squeeze film air damping in MEMS," *Sens. Actuators A, Phys.*, vol. 136, no. 1, pp. 3–27, 2007.
  - [19] Z. Hao, A. Erbil, and F. Ayazi, "An Analytical Model for Support Loss in Micromachined Beam Resonators with In-plane Flexural Vibrations," *Sensor and Actuator A*, vol. 109, pp. 156-164, 2003.
  - [20] R. Navid, J.R. Clark, M. Demirci, and C.T.C. Nguyen, "Third-order intermodulation distortion in capacitively-driven CC-beam micromechanical resonators," *Proceedings of the 14th IEEE*

International Conference on Micro Electro Mechanical Systems (MEMS 2001) Interlaken, Switzerland, 21–25 January 2001, pp. 228-231