

Development of Average Model for Control of a Full Bridge PWM DC-DC Converter

Ali Asghar Ghadimi¹, Hassan Rastegar¹, Ali Keyhani²

1- Department of Electrical Engineering
Amirkabir University of Technology, Tehran, Iran

2- Department of Electrical and Computer Engineering
The Ohio State University, Columbus, Ohio, USA

Abstract:

This paper presents a detailed small-signal and transient analysis of a full bridge PWM DC-DC converter designed for high voltage, high power applications using an average model. The derived model is implemented in a typical system and used to produce the small-signal and transient characteristics of the converter. Results obtained in the analysis of the high voltage and high power design example is validated by comparison for actual system and derived model. The derived small signal model is used to design a controller to regulate output voltage of the converter under several disturbances. A PD controller with combination of a feedforward input voltage is designed so that the output voltage is equal to desired voltage and the time response is very short under load and input voltage disturbances.

Keywords: Full Bridge DC-DC Converter, Modeling, Steady-State and Dynamic analysis, Voltage Regulation, Control

1. Introduction

Today, new advances in power generation technologies and new environmental regulations encourage a significant increase of distributed generation resources around the world. Distributed generation systems have mainly been used as a standby power source for critical businesses. For example, most hospitals and office buildings have stand-by diesel generators as an emergency power source for use only during outages. However, the diesel generators is not inherently cost-effective, and produce noise and exhaust that would be objectionable on anything except for an emergency basis. On the other hand, environmental-friendly distributed generation systems such as fuel cells, micro turbines, biomass, wind turbines, hydro turbines or photovoltaic arrays can be a solution to meet both the increasing

demand of electric power and environmental regulations due to green house gas emission [1-3]. Advances in power electronics and energy storage devices for transient backup have accelerate penetration of the distributed generation into electric power generation plants. Most of this generation's unit has DC output and in order to produce higher AC voltage than the DC output voltage, they must have a DC/DC boost converter and a DC/AC inverter as shown in figure 1.

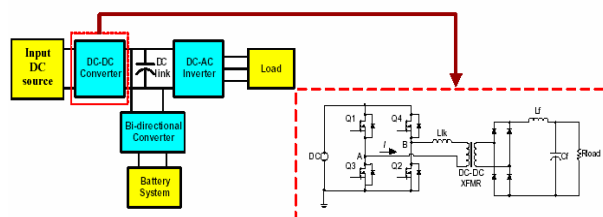

Fig. 1: Basic block diagram of a power conversion system

DC-DC converters can be used to boost and regulate low output voltage of any DC source like some new distributed generation units to high voltage and compensate for its slow response during the transient. The main task of these converters is to maintain the output voltage at constant and predefined level. To boost low voltage DC to high voltage DC a forward boost converter, a push-pull boost converter or an isolated full-bridge DC to DC power converter can be selected. Among these power converters, Full-Bridge converters are the most attractive topology for high power generation [4-6].

For control purpose and analyzing the behavior of converter, dynamic analysis of converter must be done. The choice of the average modeling method to study both large and small-signal characteristics of modern power converters has become widely accepted due to its adaptability to computer simulation. When an average

model is simulated, it requires with less computation time than the switched circuit model [5]. Dynamic performance of PWM dc-dc converter has been analyzed using state space averaging method in continues and discrete time domain [5-8].

In this paper, a large signal and small signal model of full-bridge dc-dc converter are studied. In this study, the parasitic resistances of switches are considered.

This paper is presented in seven sections. In Section 2, a discussion of Full-Bridge converter's operation is presented and in Section 3 the average model is described. The validity of derived model is verified by mean of simulation in section 4. Steady state analysis and dynamic model are presented in section 5, and in section 6 the proposed average model is validated by comparison to the switched circuit model. In section 7 design of controller for regulating output voltage and simulation result presented and finally in section 8, the conclusion of paper is presented.

2. Full-Bridge Converter Operation

Figure 2 shows the circuit schematics of a full bridge converter that consist of a full bridge power converter (Q_1 to Q_4), a high frequency transformer (with ratio 1:n), a bridge diode, and an output filter (L,C). The diagonally opposite switches (Q_1 and Q_2 , or Q_3 and Q_4) are turned on and off simultaneously in a portion of each half cycle of switching frequency as shown in Figure 2 (for time interval $D.T_s$). When all four switches are turned off, the load current freewheels through the rectifier diodes (for time interval $T_s/2-D.T_s$). The PWM pulse generator has input of Duty Cycle (D) and will produces appropriate pulses and sends them to switches. Figure 3 shows signal waveform for producing appropriate pulses according to desired duty cycle (D).

As shown in figure 3, a constant signal (Reference) is compared with a rectangular high frequency signal (Carrier). When carrier signal go over reference signal a pulse will produce and similarly negative value of reference signal will compare with carrier for producing other half cycle pulse. As shown in this figure, by changing reference signal from 0 to 1 we can have pulse with duty cycle of $0.5*T_s$ to zero. These two pulses give to pair of switch and the switches will conduct in each half period with duration of $D.T_s$.

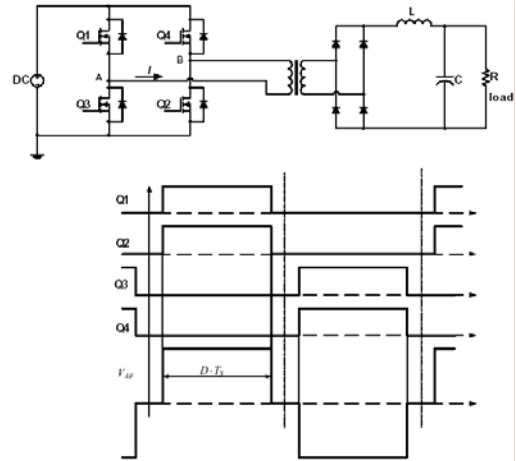

Fig. 2: Operation of full bridge converter

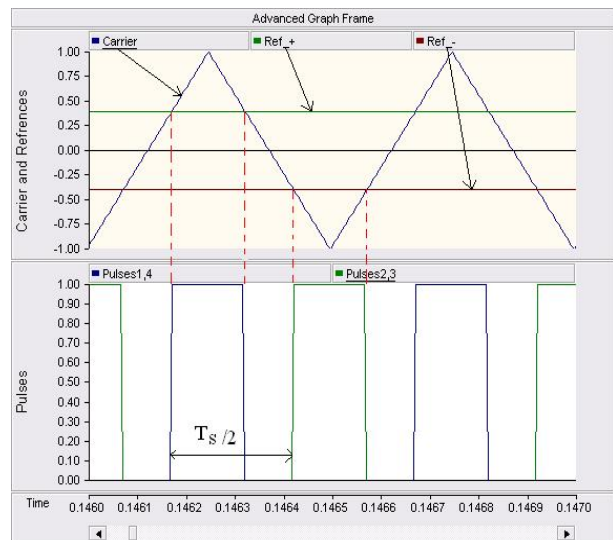

Fig. 3: PWM generation for full bridge converter

In order to reduce the size and the weight of magnetic components, it is desirable to increase the switching frequency for DC-DC converters. However, when the switching frequency is increased, switching losses would increase, and snubbers and protection are required, which introduce significant losses and lower the efficiency.

3. Deriving Average Model for Full-Bridge Converter

For modeling the full bridge converter and driving averaged model, it is assumed:

- Transistor and diodes are identical
- Transistors and diodes have on resistance r_T , r_D respectively.
- The output filter so designed that inductor current is continues in each switching period.



In this circuit, there are two state variables including capacitor voltage and inductor current. As illustrated in previous section, full bridge converter has two modes of operations in each half cycle [9]:

3.1. Mode 1

In this mode, switches Q_1 and Q_2 are in on mode and delivering energy to load via transformer and two diodes. For this mode, the circuit model is as shown in figure 4. Using KVL and KCL, the state equation of the circuit can be derived as presented below. In this model the state variables are inductance current (X_1) and capacitor voltage (X_2):

$$\begin{aligned} KVL: \quad nV_d &= R_{th}X_1 + L\dot{X}_1 + X_2 \\ KCL: \quad X_1 &= C\dot{X}_2 + \frac{X_2}{R} \end{aligned} \quad (1)$$

where $R_{th} = 2n^2r_T + 2r_D$

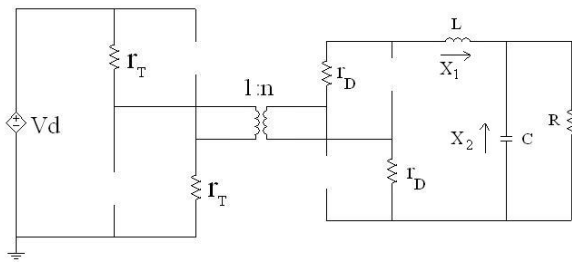

Fig. 4: Mode 1 of operation

Therefore the state space model and matrices in the interval $d.T_s$ are:

$$\begin{aligned} \dot{X} &= A_1X + B_1V_d, \quad V_0 = C_1X \\ A_1 &= \begin{bmatrix} -\frac{R_{th}}{L} & -\frac{1}{L} \\ \frac{1}{C} & -\frac{1}{RC} \end{bmatrix}, \quad B_1 = \begin{bmatrix} \frac{n}{L} \\ 0 \end{bmatrix} \\ C_1 &= [0 \quad 1] \end{aligned} \quad (2)$$

3.2. Mode 2

In this mode, all switches are off and load current flow through bridge diodes and circuit can be modeled as figure 5.

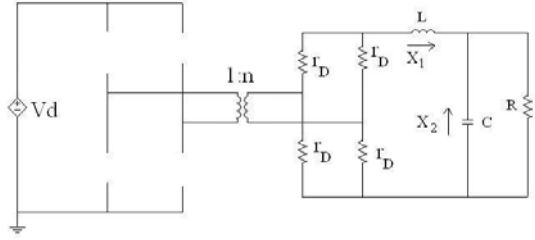

Fig. 5: Mode 2 of operation

Again KVL and KCL yield this equation:

$$\begin{aligned} KVL: \quad 0 &= r_D X_1 + L\dot{X}_1 + X_2 \\ KCL: \quad X_1 &= C\dot{X}_2 + \frac{X_2}{R} \end{aligned} \quad (3)$$

And therefore state matrices in this mode are:

$$\begin{aligned} A_2 &= \begin{bmatrix} -\frac{r_D}{L} & -\frac{1}{L} \\ \frac{1}{C} & -\frac{1}{RC} \end{bmatrix}, \quad B_2 = \begin{bmatrix} 0 \\ 0 \end{bmatrix} \\ C_2 &= [0 \quad 1] \end{aligned} \quad (4)$$

Finally, based on averaged model concept [5,9], and because the last half cycle is identical to first half, averaged model of this converter in $T_s/2$ can be obtained as:

$$\begin{aligned} \dot{X} &= AX + BV_d, \quad V_0 = CX \\ A &= A_1 2d + A_2 (1-2d) = \\ &= \begin{bmatrix} -\frac{R_{th} 2d + r_D (1-2d)}{L} & -\frac{1}{L} \\ \frac{1}{C} & -\frac{1}{RC} \end{bmatrix} \end{aligned} \quad (5)$$

$$\begin{aligned} B &= B_1 2d + B_2 (1-2d) = \begin{bmatrix} \frac{2dn}{L} \\ 0 \end{bmatrix} \\ C &= C_1 2d + C_2 (1-2d) = [0 \quad 1] \end{aligned}$$

This averaged model state equation can be used for simulation of converter instead of the model with multiple switches that may have long simulation time and also this state equation can be used for analysis of original one performance and development of controller and stability studies.

Based on above average model, the following electrical circuit model can be derived and used for simulation, design of controller, and stability studies.

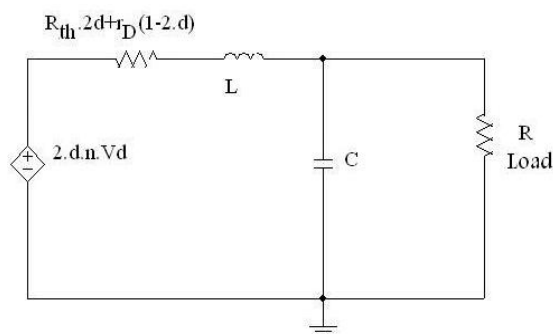

Fig. 6: Large signal average model of full bridge converter

4. Model Validation

To validate the proposed method, a 5 kW system with the parameter shown in table 1 is considered for the study. The PSCAD/EMTDC that is an industry standard simulation tool for studying the transient behavior of electrical networks [10] is used for simulation. In this study, the Output filter of the converter is so designed that there is 2% ripple in inductor current and 1% ripple in output voltage [11].

Table 1: System Parameter

Input Voltage-Vd (Volts)	50	Filter Inductance - L (milli Henry)	7
Transformer Power (kVA)	5	Filter Capacitance-C (micro Farad)	330
Transformer Voltages	50:500	Load Resistance-R (ohms)	12.5
Switching Frequency (Hz)	2000	Switches on Resistor (ohms)	5e-3

For verifying the proposed model, actual system and averaged model in large signal are simulated in 3 cases:

4.1. Step Change in Duty Cycle (D)

In this case the actual system and averaged model simulated with $d=0.2$ and then in time 1 second the duty cycle change from 0.2 to 0.3. Figure 7 shows the simulation results in this case and the actual system and derived model results represented together for compare. Results show near perfect agreement, with the average model closely tracking those of the actual circuit and the model is valid in this large signal change in duty cycle (D).

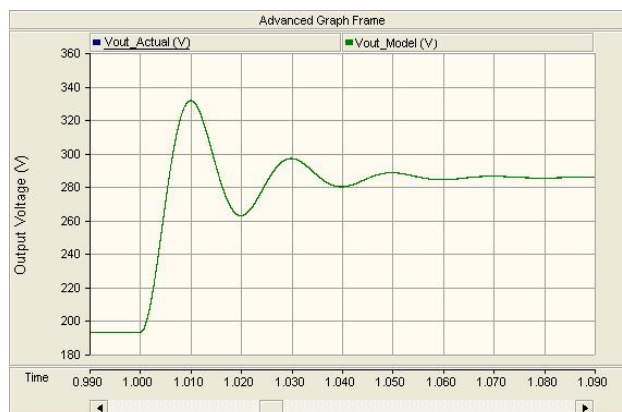

Fig. 7: Step change in duty cycle from 0.2 to 0.3 and voltage in modeled system and actual one

4.2. Change in Load

In this case a load transient from 100% to 50% full load is simulated at 1 second by turning off the load switch. Results from the transient simulation from both methods are shown superimposed in figure 8. As the figure shows, two waveforms are exactly identical and it is impossible to separate them. The figure also shows that output voltage drop when load is increased in this open loop system.

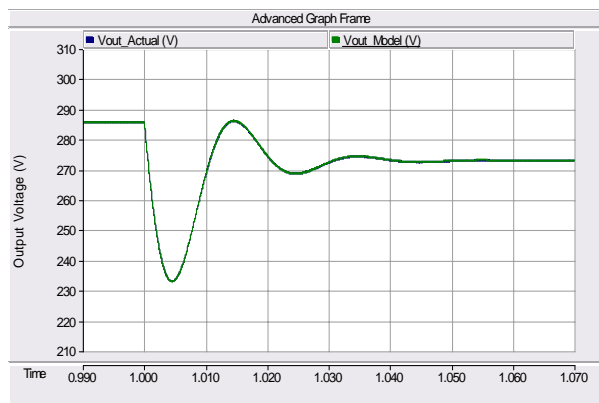

Fig. 8: Simulation results for step change in load resistance

4.3. Change in Input Voltage

In final case study, a change in input voltage is simulated during changing input voltage from 50 volts to 40 volts in 0.5 sec and the results also show that two waveforms are identical (Figure 9).



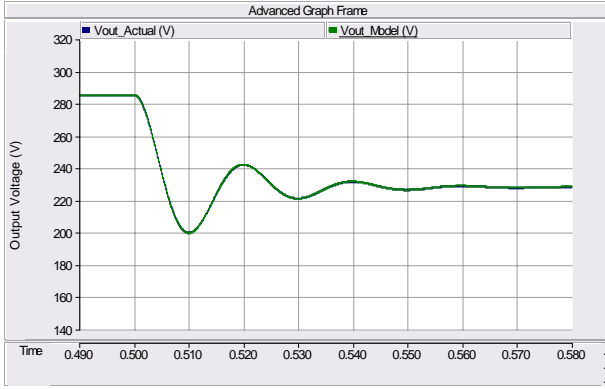

Fig. 9: Simulation waveform for step change in input voltage

5. Steady-State Analysis

With the model of state space equation and matrices A,B,C a small ac perturbation (represented by \sim) and dc steady state (In upper case letters) quantities for model parameter considered as:

$$\begin{aligned} x &= X + \tilde{x} \quad , \quad v_o = V_o + \tilde{v}_o \\ d &= D + \tilde{d} \quad , \quad v_d = V_d + \tilde{v}_d \end{aligned} \quad (6)$$

Substitution of this parameter into state equation (Eq. 5) yield:

$$\begin{aligned} \dot{\tilde{x}} &= A\tilde{x} + B\tilde{v}_d + (A\tilde{x} + B\tilde{v}_d) + [(A_1 - A_2)X + (B_1 - B_2)V_d]2\tilde{d} \\ &+ \text{terms with product of } \tilde{x}, \tilde{d}, \tilde{v}_d (\text{negligible}) \\ V_o + \tilde{v}_o &= C\tilde{x} + C\tilde{v}_d + [(C_1 - C_2)X]2\tilde{d} + \\ &+ \text{terms with product of } \tilde{d}, \tilde{v}_d (\text{negligible}) \end{aligned} \quad (7)$$

The steady state equation can be obtained from Eq. 7 by setting all ac components to zero. Therefore the steady state equation is:

$$AX + BV_d = 0 \quad \text{and for output: } V_o = CX \quad (8)$$

And therefore in Eq. 7 the small signal components have this relation:

$$\begin{aligned} \dot{\tilde{x}} &= A\tilde{x} + B\tilde{v}_d + [(A_1 - A_2)X + (B_1 - B_2)V_d]2\tilde{d} \\ \tilde{v}_o &= C\tilde{x} + [(C_1 - C_2)X]2\tilde{d} \end{aligned} \quad (9)$$

Using Eq. 8 and value of matrices in Eq. 5 the steady state dc voltage transfer function is:

$$m = \frac{V_o}{V_d} = -CA^{-1}B = 2Dn \frac{R}{R + R_{th}2D + r_D(1-2D)} \quad (10)$$

Figure 10 shows the dc output to input gain (m) versus duty cycle (D) in several load resistance. As the figure shows there is approximately linear relationship between dc gain and duty cycle and as D increase from 0 to its maximum value (0.5), output voltage to input voltage gain will increase approximately in a linear manner. From the curves, it is clear that an increase in load (by decreasing load resistance) result in a decreased gain for a constant duty cycle. Therefore, the steady state voltage must be regulated by changing duty cycle (D).

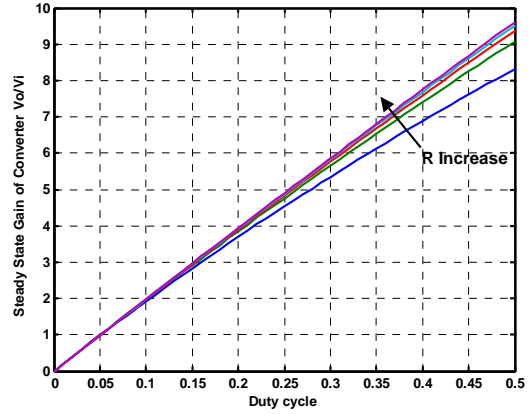

Fig. 10: Steady state gain of converter in various load resistance versus duty cycle (D)

6. Small Signal Analysis

From Eq. 9 that consists of ac perturbations and using laplace transform:

$$\begin{aligned} \tilde{x}(s) &= (SI - A)^{-1}[(A_1 - A_2)X + (B_1 - B_2)V_d]2\tilde{d}(s) + \\ &(SI - A)^{-1}B\tilde{v}_d(s) \\ \tilde{v}_o(s) &= C\tilde{x}(s) + [(C_1 - C_2)X]2\tilde{d}(s) \end{aligned} \quad (11)$$

From Eq. 11 output voltage laplace transform in term of input voltage and duty cycle is as below:

$$\begin{aligned} \tilde{v}_o(s) &= \{C(SI - A)^{-1}[(A_1 - A_2)X + (B_1 - B_2)V_d] + \\ &(C_1 - C_2)X\}2\tilde{d}(s) + C(SI - A)^{-1}B\tilde{v}_d(s) \end{aligned} \quad (12)$$

For obtaining transfer function of output voltage to duty cycle, the perturbation of input voltage is assumed to be zero and therefore:

$$\begin{aligned} \frac{\tilde{v}_o(s)}{\tilde{d}(s)} &= 2C(SI - A)^{-1}[(A_1 - A_2)X + (B_1 - B_2)V_d] \\ &+ 2(C_1 - C_2)X \end{aligned} \quad (13)$$

Substituting matrices from Eq. 5 and simplification, the

transfer function can be derived as Eq. 14:

$$\frac{\tilde{v}_o(s)}{\tilde{d}(s)} = \frac{2}{LC} \frac{nV_d + (r_D - R_{th})X_1}{den(s)} \quad (14)$$

Where:

$$den(s) = s^2 + \left(\frac{1}{RC} + \frac{R'}{L}\right)s + \left(\frac{R'}{RLC} + \frac{1}{LC}\right)$$

and $R' = R_{th}2D + r_D(1-2D)$

V_d , X_1 , and D are steady state value for input voltage, inductance current and duty cycle respectively. Based on the small signal model derived in previous section, it can be seen that the full bridge converter acts like a second order system. But as transfer function equation shows, dynamic of converter depend on operating point since inductor current and duty cycle steady state value of operating exist in proposed model. To validate the average model a step change in duty cycle (d from 0.3 to 0.28) has been introduced and the results are shown in figure 11.

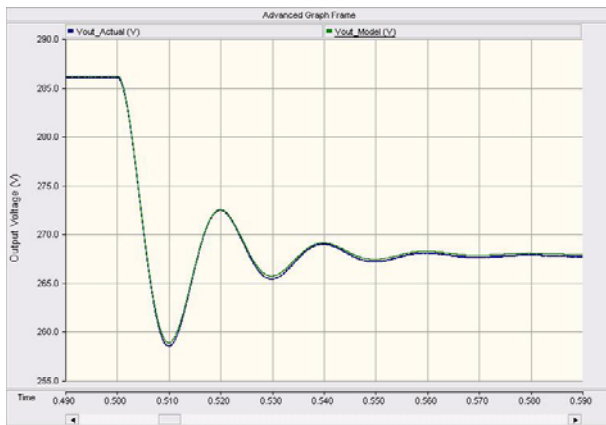

Fig. 11: Small signal model and actual model simulation for small change (0.02) in d

As shown in figure 11 the derived small signal response is very close to the switched circuit model; hence the transfer function can be used for dynamic analysis of the converter and designing controller.

Another case is studied for a large change in duty cycle from 0.3 to 0.2, and result of voltage for this case is shown in figure 12. As the figure shows, in this case the small signal model has difference with actual one but this difference is very small.

According to small-signal and steady state characteristics of this converter, compensation techniques for output voltage control are needed.

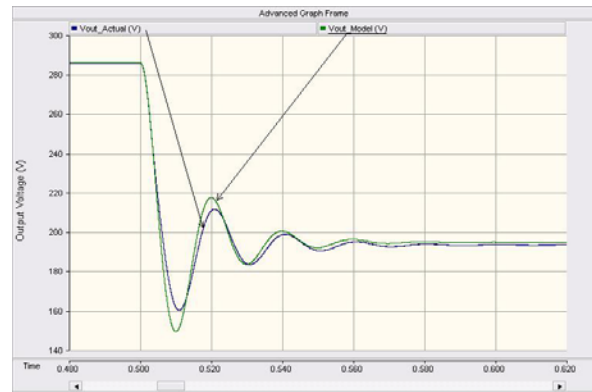

Fig. 12: Small signal model and actual model simulation for large change (0.1) in d

7. Controller Design

For regulating output voltage of full bridge dc-dc converter, a compensation technique for output voltage control is implemented in this section. A negative feedback control circuit is widely used to regulate the output voltage against both line and load variations. Feedforward control can also be used to reduce the disturbances and thereby improve the output voltage characteristics of PWM dc-dc converters [13–15]. The feedforward control technique uses disturbance signal to prevent a change in the output voltage. The disturbance signal is monitored and a control signal is derived to adjust the duty ratio such that the output voltage is not affected by the disturbance. In contrast, the negative feedback technique detects a change in the output voltage and then tries to reduce this change. A combination of both negative feedback and feedforward techniques is able to achieve superior performance.

Based on the small signal model derived in previous section, it can be seen that the full bridge converter act like a second order system and a simple PD controller can be designed for regulating the output voltage under step load change or input voltage change. Figure 13 presents the block diagram of combined control system for regulate the output voltage of the converter.

The control system detects output voltage and compares it with the desired reference voltage and compensates it by changing in duty ratio of switches. The feedforward controller multiplies a gain to final duty ratio. Since system is linear and second order a PD Controller designed for the system according to minimizing the integral of time multiplied by the absolute value of error (ITAE) criterion [16]. The optimal parameter for proportional and derivation factor derived according to that method as 1.05 and 2.34 respectively.

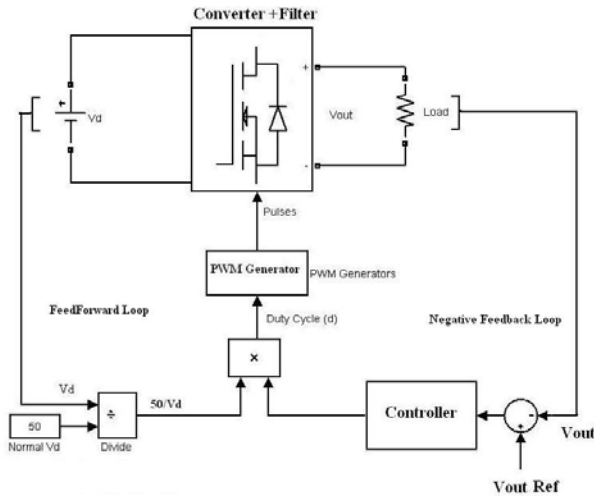

Fig. 13: Closed loop system block diagram

The closed loop system with designed controller is simulated for two cases.

7.1. Step Change in Load

In this case, a step change in load is performed at $t=0.1$ sec and the load is changed to its initial value at $t=0.3$ sec. Simulation results are shown in figure 14. The controller can regulate voltage in the desired voltage. The output voltage has reached to desired value in approximately 0.03 seconds and it has very fast. Figure 14 also shows controller output e.g. Duty Cycle (d) of converter, and regulated output voltage.

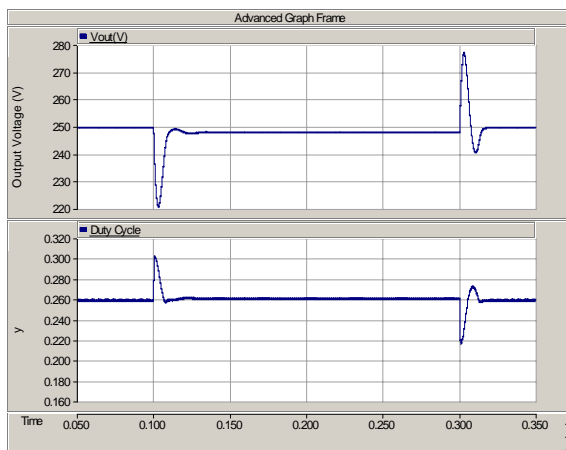

Fig. 14: Closed loop system response to change in load

7.2. Step Change in Input Voltage

In this case, a step change in input voltage happened at 0.5 sec from 50 volts to 40 volts, and again changed back to initial value at $t=1$ sec. Simulation results are shown in

figure 15. It can be seen that the controller can regulate voltage in the desired voltage in proper time with changing the duty cycle of converter.

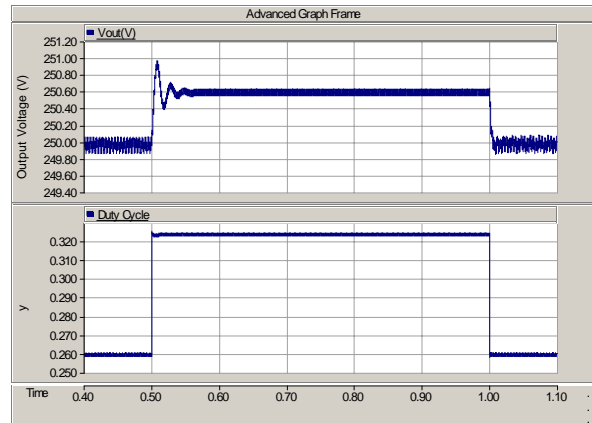

Fig. 15: Closed loop system response to change in input voltage

8. Conclusions

This paper presents an average model for full bridge dc-dc converter. The model used for steady state, dynamic analysis, and large signal analysis of this converter. The developed model is used to study the characteristics and dynamics of full bridge converter and also is applicable to simulation and controller design. Simulation results for the full bridge converter show the feasibility of the proposed model for steady-state analysis and small signal analysis and verify the derived model. Validation of the derived model is based on a comparison of dc, small-signal, and large-signal simulation results to those obtained from the simulation of the actual circuit.

In last section, a PD controller with combination of input voltage feedforward control have been presented and it is shown that the controller is effective in regulating the output voltage of converter in changing load and input voltage disturbances.

References

- [1] M. N. Marwali and A. Keyhani, "Control of Distributed Generation Systems, Part I: Voltages and Currents Control," IEEE Transaction on Power Electronics, Vol. 19, No. 6, pp. 1541-1550, 2004.
- [2] M. N. Marwali, J. W. Jung, and A. Keyhani, "Control of Distributed Generation Systems, Part II: Load Sharing Control," IEEE Transaction on Power Electronics, Vol. 19, No. 6, pp. 1551-1561, 2004
- [3] A. A. Chowdhury, S. K. Agarwal, D. O. Koval, "Reliability modeling of distributed generation in conventional distribution systems planning and analysis," IEEE Transactions on Industry Applications, vol. 39, pp. 1493-1498, Sept.-Oct. 2003

- [4] J. W. Jung, and A. Keyhani, "Modeling and Control of Fuel Cell Based Distributed Generation Systems in a standalone Ac Power System," *Journal of Iranian Association of Electrical and Electronics Engineers*, Vol. 2, No. 1, pp: 10-23, 2005
- [5] Chris Iannello, Shiguo Luo, and Issa Batarseh, "Small-Signal and Transient Analysis of a Full-Bridge, Zero-Current-Switched PWM Converter Using an Average Model", *IEEE Transaction on Power Electronics*, Vol. 18, No. 3, 2003
- [6] Guinjoan, F.; Poveda, A.; Martinez, L.; Vicuna, L.G.; Majo, J., "An accurate small-signal modelling approach for switching DC-DC converters," *IEEE International Symposium on Circuits and Systems*, 1993
- [7] Piero G. Maranesi, Marco Riva, "Automatic Modeling of PWM DC-DC Converters," *IEEE Power Electronics Letters*, Vol. 1, No. 4, 2003
- [8] Czarkowski, D.; Kazimierczuk, M.K. , "SPICE compatible averaged models of PWM full-bridge DC-DC converter," *Proceedings of the 1992 International Conference on Industrial Electronics, Control, Instrumentation, and Automation*, 1992
- [9] Mohan, Undeland, Robbins, *Power Electronics Converter. Application, and Design*, third edition, wiley, 2003
- [10] Manitoba HVDC research center Inc., "PSCAD/EMTDC V4.1.0", 2006
- [11] A. Pressman, *Switching power Supply Design*, Second edition, McGraw-Hill, 1998
- [12] R. C. Dorf, R.H. Bishop, *Modern Control Systems*, 9th Edition, 2000
- [13] Marian K. Kazimierczuk and LaVern A. Starman, "Dynamic Performance of PWM DC-DC Boost Converter with Input Voltage Feedforward Control," *IEEE TRANSACTIONS ON CIRCUITS AND SYSTEMS*, VOL. 46, NO. 12, DECEMBER 1999
- [14] M. K. Kazimierczuk and A. Massarini, "Feedforward control of dc-dc PWM boost converter," *IEEE Transactoon on Circuits and System*, vol. 44, pp. 143-148, Feb. 1997.
- [15] B. Arbetter and D. Maksimovi'c, "Feedforward pulse width modulators for switching power converters," *IEEE Trans. Power Electron.*, vol. 12, Mar. 1997
- [16] Dorf, Richard C., *Modern Control System*, 9th Edition, Prentice Hall, 2000

