

# Long Term Cost Effective Preventive Maintenance Scheduling

M. Mollahassani-pour<sup>1</sup>

M. Rashidinejad<sup>2</sup>

A. Abdollahi<sup>3</sup>

S. Nikbakhsh<sup>4</sup>

<sup>1</sup> Ph.D. Student, Department of Electrical Engineering, Shahid Bahonar University of Kerman, Kerman, Iran  
[m.mollahassani@gmail.com](mailto:m.mollahassani@gmail.com)

<sup>2</sup> Professor, Department of Electrical Engineering, Shahid Bahonar University of Kerman, Kerman, Iran  
[mrashidi@uk.ac.ir](mailto:mrashidi@uk.ac.ir)

<sup>3</sup> Assistant Professor, Department of Electrical Engineering, Shahid Bahonar University of Kerman, Kerman, Iran  
[a.abdollahi@uk.ac.ir](mailto:a.abdollahi@uk.ac.ir)

<sup>4</sup> Lecturer, Department of Industrial Engineering, Shahid Bahonar University of Kerman, Kerman, Iran  
[Nikbakhsh.n@gmail.com](mailto:Nikbakhsh.n@gmail.com)

## Abstract :

Preventive maintenance scheduling of generating units is addressed as a long-term scheduling in power system studies aiming to increase the reliability incorporating cost reduction. It consists of knowing which generating units should be shut down for regular safety inspection. In this paper, a new formulation of preventive maintenance scheduling associated with cost reduction index (CRI) is presented. Mainly, the purpose of the maintenance problem is minimizing the operation as well as maintenance costs over a specified time horizon. CRI is introduced in such a way to reduce the operation cost along the scheduling time while determining the most proper maintenance scheme. The proposed framework is structured as a mixed integer linear programming (MILP) and solved using CPLEX solver. The suggested model is applied to a standard IEEE reliability test system (RTS) and the promising results show the effectiveness of the proffered model.

**Keywords:** Preventive maintenance scheduling, Pre-generation scheduling, MILP, Cost reduction index.

---

**Submission date :** 23, April, 2013

**Conditionally Acceptance date:** 16, Jan., 2014

**Acceptance date :** 9, Nov, 2014

**Corresponding author :** M. Rashidinejad

**Corresponding author's address:** 22 Bahman Blvd., Elec. Eng. Dep., Shahid Bahonar Uni. Kerman, Iran.



# 1. Introduction

Preventive maintenance of generating units is addressed as a crucial issue due to affecting on power systems' asset management by reducing operation as well as reliability cost while improving reliability worth. In fact, it may affect reducing cost of damaging due to unforeseen breakdown [1]. Basically, equipment failure, testing, unanticipated events, refueling, operator errors and regulatory restriction; may cause a generating unit's unavailability. Although refueling is compulsory, but planned periodic outage of generating units may control and reduce the ratio of unanticipated events that improves reliability as well as system performance [2, 3]. Preventive maintenance schedule of generating units is extremely important due to affecting on short-term generation scheduling such as unit commitment [4].

However, due to large number of components and constraints, finding the most suitable approach for maintenance scheme is not easy achievable. In recent years, several deterministic, heuristic and hybrid methods have been utilized for solving the preventive maintenance scheduling problem as a large scale, non-convex, and mixed-integer combinatorial optimization problem. In [1], Benders' decomposition has been used to overcome the complexity of maintenance problem, while [3] proposes a multi-objective programming model based on decision tree and mixed integer linear programming for midterm preventive maintenance in thermal power plants. A hybrid algorithm is presented in [4] to solve the generator maintenance scheduling which employs a new local search method in genetic algorithm. In [5-8], genetic algorithm (GA) has been employed via different models to optimize the time of units' outage in order to obtain the surveillance program. In [9], simulated annealing (SA) has been used while in [10], a combination of GA and SA has been exercised to solve the maintenance problem. Reference [11], expressed a method based on the Monte Carlo simulation by integrating GA to tackle to the preventive maintenance problem. In [12, 13], a hybrid Fuzzy-genetic algorithm has been proposed for maintenance problem of thermal power plants. In [14], Tabu search (TS) has been used and [15, 16] stated an improved formulation by using ant colony (AC) technique to schedule the optimum power plant maintenance scheme. In [17-19], a particle swarm optimization is used to determine the best maintenance schedule of power plants while in [20], a fuzzy dynamic programming (FDP) methodology for finding the best preventive maintenance scheduling of generating units in a centralized power system.

In this paper, a new formulation of preventive maintenance scheduling problem associated with the cost reduction index (CRI) is presented. The preventive maintenance scheduling problem aims to determine the maintenance scheme of generating units while the operation cost is minimized. If maintenance time of a

unit is placed in an inappropriate period, the operation cost might be increased due to unavailability of the aforementioned unit. In such a case, the required demand is supplied with more expensive units. Therefore, a cost reduction index is introduced here to prevent such complications. The impacts of CRI on maintenance scheduling problem is significant where it may change units' status as well as maintenance scheme to reduce the total operating cost. The presented framework is structured as mixed integer linear programming (MILP). One of the main features of the MILP method includes direct measure of optimality of a solution and more flexible and accurate modeling capabilities. Here, CPLEX as a sophisticated and computationally efficient MILP solver is applied for solving the proposed model.

The rest of the paper is organized as follows: The proposed MILP based formulation for the preventive maintenance scheduling problem associated with the cost reduction index is provided in section 2. Section 3 conducts the numerical simulations and finally, concluding remarks are explained in section 4.

## 2. Model Description

Preventive maintenance scheduling is an optimization problem to determine the appropriate maintenance scheme of generating units with respect to a series of prevailing constraints. The objective of maintenance problem is minimizing both the operation as well as the maintenance expenditures. Here, a mixed integer linear programming (MILP) structure is presented to handle the maintenance scheduling problem. A common way of solving MILP problem is to relax some coupling constraints and decompose it into several sub problems, while in recent years some efficient MILP solvers are developed. In this paper, the employed optimization solver is General Algebraic Modeling System (GAMS); and CPLEX as a commercial and computationally efficient MILP solver is used for solving the maintenance problem.

### 2.1. Objective Function and Constraints

The objective function of the proposed framework is presented as (1):

$$\text{Min: } \sum_{t \in T} \sum_{n \in N} \{FC(n)P(n,t)CRI(n,t) + MC(n)x(n,t)\bar{P}(n)\}h \quad (1)$$

where:  $h$ ,  $T$ ,  $N$ ,  $FC(n)$ ,  $P(n,t)$ , and  $MC(n)$  represent, respectively, the hour, scheduling time horizon, number of the units, the fuel cost of a unit ( $\$/MWh$ ), the generated power of a unit ( $MW$ ) at period  $t$ , and the maintenance cost of a unit.  $CRI(n,t)$  is an index namely cost reduction index that is explained in details in the next subsection.  $x(n,t)$  is maintenance binary variable which is equal to one if a unit is under maintenance at period  $t$  and it takes zero otherwise.

The objective function is subjected to the maintenance [1] and power generation [21] constraints as follows:

- Power balance constraint: The generated power of committed units must be equal to the demand in each period.  $D(t)$  represents the demand (MW) at period  $t$ .

$$\sum_{n \in N} P(n, t) = D(t) \quad (2)$$

- Generated power constraint: The unit power must be between its maximum and minimum capacity. Moreover,  $\underline{P}(n)$  and  $\bar{P}(n)$  are the minimum and the maximum generating capacity of a unit, respectively.

$$\underline{P}(n) \leq P(n, t) \leq \bar{P}(n) \quad (3)$$

- Reserve constraint: Maximum capacity of committed units should be equal or greater than the summation of the demand and the system reserve. System reserve ensures the reliability when a failure happens in a generator. Generally, it is considered as the largest unit capacity or a portion of the maximum demand.  $c(n, t)$  is an auxiliary binary variable, to show the connection status of a unit. The connection status is one when the unit is committed and it takes zero otherwise.

$$\sum_{n \in N} \bar{P}(n) c(n, t) \geq D(t) + Res(t) \quad (4)$$

- Maintenance duration: The unit maintenance duration is definite in a specified time horizon. Required maintenance duration for a unit is symbolized by  $Md(n)$ .

$$\sum_{t \in T} x(n, t) = Md(n) \quad (5)$$

- One time maintenance constraint: Each unit is taken under maintenance just once during the scheduling time horizon.  $s(n, t)$  is binary variable which is equal to one if a unit's maintenance starts at the beginning of period  $t$ , and takes zero otherwise.

$$\sum_{t \in T} s(n, t) = 1 \quad (6)$$

- Non-stop maintenance constraint: The unit maintenance is performed in uninterrupted periods.

$$x(n, t) - x(n, t-1) \leq s(n, t) \quad (7)$$

- Maintenance and connection constraint: This constraint illustrates the relation between the maintenance status and the commitment status. Equation (8) is utilized for thermal power plants, while (9) is used in nuclear units. Since nuclear units are low cost with higher startup time as well as shutdown time; nuclear units are always committed except their maintenance durations. However thermal units can be connected or not, even though they are not under inspection.

$$x(n_1, t) + c(n_1, t) \leq 1 \quad n_1 \in Thermal \ units \quad (8)$$

$$x(n_2, t) + c(n_2, t) = 1 \quad n_2 \in Nuclear \ units \quad (9)$$

- Exclusive constraint: Generating units  $i$  and  $j$  cannot be in maintenance at the same time.

$$x(i, t) + x(j, t) \leq 1 \quad (10)$$

- Crew constraint: Since the total available manpower as well as the required crews for specified unit maintenance in a period is definite, number of the units which can be inspected simultaneously is limited in a period. Number of crew needed for a unit inspection at a period, and the total available manpower in a period are symbolized by  $CM(n)$  and  $CM_{Total}$  respectively.

$$\sum_{n \in N} CM(n) x(n, t) \leq CM_{Total} \quad (11)$$

## 2.2. Cost Reduction Index (CRI)

Preventive maintenance scheduling of generating units is performed before generation scheduling. If maintenance time of units is selected inappropriately, the operation cost might be increased due to unavailability of inexpensive units in generation scheduling. Therefore, it is extremely crucial to determine the best maintenance scheme in order to take the lowest operation cost in generation scheduling problem. A cost reduction index (CRI) is suggested here to facilitate contributing less expensive units. The proposed index is introduced via (12).

$$CRI(n, t) = 1 + \left( \frac{\bar{P}(n) - P_0(n, t)}{\bar{P}(n)} \right) \quad (12)$$

In the following, the procedure of achieving CRI is explained in details. At the first step, it is supposed that all units are continuously available, and do not require to be taken under maintenance in the whole time horizon. By this assumption, the generation pattern of units is determined such that to satisfy the load in the time horizon which is called as pre-generation scheduling, while the operation costs is minimized. It can be mentioned that, the appropriate time of unit selection for maintenance is when it is off or generate less power in comparison with its maximum capacity in pre-generation scheduling. In pre-generation scheduling, each unit is categorized in one of the following cases.

- Case A; the unit is off in pre-generation scheduling, where it can be considered as the best choice for maintenance time.
- Case B; the unit generates power at its maximum capacity where it is not suitable time for the unit maintenance. Otherwise, an additional cost should be sustained in generation scheduling due to unit unavailability.
- Case C; the generated power of a unit is less than its maximum capacity. If the unit is taken under



maintenance at this time, an extra cost is sustained in generation scheduling which is less than case B. Therefore, it is also preferred that the unit be committed in maintenance scheduling the same as case B.

In all above cases, a penalty factor is defined in order to prevent an undesirable status. Such penalty factor is named cost reduction index (CRI) where it is proportional to the generated power of a unit in pre-generation scheduling. As shown by (1), CRI influences the fuel cost of a unit that encourages the unit to be selected in a desirable situation in maintenance scheduling. In case A, maximum CRI is enforced to prevent the commitment of the off-units, while in case B, the minimum CRI is imposed to decrease the trend of maintenance towards the on-units. In case C, CRI is between its maximum and minimum values.

In this paper, the minimum CRI is assumed equal to one. Hence, CRI is formulated by (13). In (13)  $VT$  is a variable term of CRI that is proportional to the output power of a unit in pre-generation scheduling. In fact,  $VT$  reflects the optimum status of units in the maintenance scheduling. Therefore, it causes the units to be placed in an appropriate situation. In case A,  $VT$  must be maximized while in case B, it has to be equal to zero for minimizing (13). The correlation between  $VT$  and the output power of each unit is shown by (14).

$$CRI(n,t) = 1 + VT \quad (13)$$

$$VT \propto \bar{P}(n) - P_0(n,t) \quad (14)$$

Where:  $P_0(n,t)$  represents the generated power of a unit in pre-generation scheduling, which can be obtained through (15)-(18).

$$\text{Min} : \sum_{t \in T} \sum_{n \in N} FC(n)P_0(n,t)h \quad (15)$$

$$\sum_{n \in N} P_0(n,t) = D(t) \quad (16)$$

$$\sum_{n \in N} \bar{P}(n)c(n,t) \geq D(t) + Res(t) \quad (17)$$

$$P(n) \leq P_0(n,t) \leq \bar{P}(n) \quad (18)$$

Since generating units have different capacities,  $VT$  must be normalized via (19). Hence, the unit tends to be taken under maintenance when the value of CRI is maximized for decreasing the operating cost.

$$VT = \left( \frac{\bar{P}(n) - P_0(n,t)}{\bar{P}(n)} \right) \quad (19)$$

### 3. Case Study

In this study, the IEEE Reliability Test System has been utilized for simulation studies with a scheduling time horizon of 52 weeks as shown in Fig. 1.

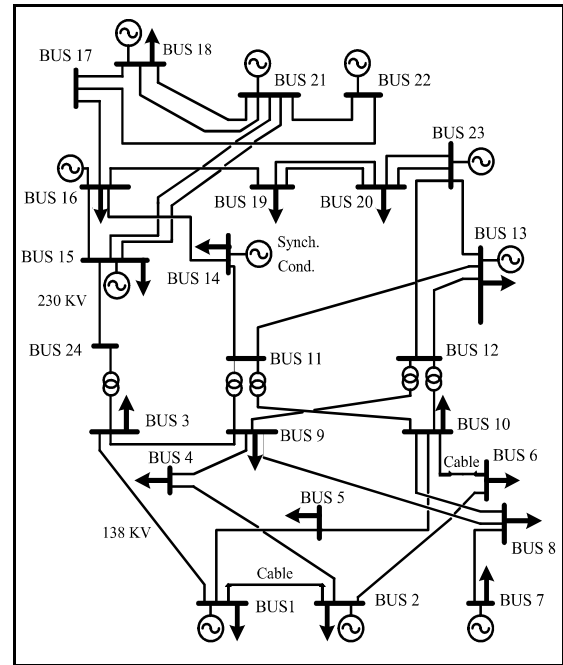

Fig.1. IEEE-RTS system

This system includes 32 generating units; 21 oil with 1922 MW namely OF<sub>1</sub>-OF<sub>21</sub>, 9 coal with 1274 MW so-called CF<sub>22</sub>-CF<sub>30</sub>, and 2 nuclear with 800 MW as N<sub>31</sub>-N<sub>32</sub>. The peak load is 2850 MW and the weekly load profile of the IEEE-RTS is used to obtain the annual load curve. More required data including operating and maintenance insights of the generating units are provided in [22]. System reserve requirement, i.e.  $Res(t)$ , is considered 400 MW which is equal to the largest unit capacity. The total available technical staff in each period is considered 30 and required manpower for inspection of a specified unit is given in Table I. Moreover, exclusive constraint is disregarded during the scheduling period.

Table I. Required staff

Unit	Required crew	Unit	Required crew
OF <sub>1</sub> -OF <sub>9</sub>	15	CF <sub>30</sub>	9
OF <sub>10</sub> -CF <sub>29</sub>	10	N <sub>31</sub> -N <sub>32</sub>	8

First, in order to investigate the impact of the proposed maintenance scheduling scheme, the problem is solved without considering CRI namely base case. CPLEX 12.4.0 optimizer is utilized to obtain the operation cost as well as maintenance scheme. In the base case the demand is supplied using available low cost generators, which is dependent on the maintenance schedule of the units. In this case, the total expenditure including maintenance as well as operation cost is obtained as 254.31 million \$/year.

In the final case, the maintenance problem is solved with considering CRI in the objective function. As mentioned in Section 2, the main purpose of maintenance scheduling is determining the exact generating units repair time for minimizing the

operating cost along the time horizon. The problem optimization results are given in Table II. As it is indicated in Table II, implementing CRI can decrease the total cost considerably.

Table II. Optimization results in final and base cases

	Base Case	Final Case
Objective Function	$2.54305002 \times 10^8$	$3.04777843 \times 10^8$
Total cost (million \$/ year)	254.305002	251.570957
Saving (million \$/year)	---	2.734045

It is deduced from Table II that CRI decreases total cost considerably. In final case, the total cost is decreased 1.07% per year in comparison with the base case. By applying CPLEX 12.4.0, in Table III, the maintenance schedule of generating units for the final case and the base case are presented. As depicted in Table III, CRI affects the maintenance scheme of units.

The average system LMP in the final case and the base case are compared along the time horizon in Fig. 2. In the final case, due to the more proper maintenance scheme, the average system LMP is decreased in comparison with the base case. As shown in Fig. 2, the average system LMP becomes more flattened and changes less in the final case in comparison with the base case.  $N_{31}$  and  $N_{32}$  are the lowest cost generating units in this system. In the base case due to  $N_{32}$  inappropriate maintenance time, LMP is increased

between periods 29 to 34 in comparison with the final case. Moreover, because of simultaneous maintenance time of  $N_{31}$  and  $CF_{28}$ , average system LMP is increased in the base case between periods 42 to 45. Furthermore between periods 12 to 17, due to the outage of  $N_{32}$  in final case, the average system LMP is raised. The average LMP in the entire scheduling time horizon in the base case and the final case are 13.9 and 13.7, respectively which is decreased 1.44% in the final case

Table III. Maintenance scheme

Unit No.	Maintenance start week		Unit No.	Maintenance start week	
	Base case	Final case		Base case	Final case
OF <sub>1</sub>	23	44	OF <sub>17</sub>	23	12
OF <sub>2</sub>	32	26	OF <sub>18</sub>	15	31
OF <sub>3</sub>	8	49	OF <sub>19</sub>	40	31
OF <sub>4</sub>	6	2	OF <sub>20</sub>	19	6
OF <sub>5</sub>	1	46	OF <sub>21</sub>	34	19
OF <sub>6</sub>	48	51	CF <sub>22</sub>	35	10
OF <sub>7</sub>	4	49	CF <sub>23</sub>	25	13
OF <sub>8</sub>	49	2	CF <sub>24</sub>	45	35
OF <sub>9</sub>	51	51	CF <sub>25</sub>	44	35
OF <sub>10</sub>	46	43	CF <sub>26</sub>	8	8
OF <sub>11</sub>	27	22	CF <sub>27</sub>	27	33
OF <sub>12</sub>	39	28	CF <sub>28</sub>	42	8
OF <sub>13</sub>	4	22	CF <sub>29</sub>	14	24
OF <sub>14</sub>	50	4	CF <sub>30</sub>	35	28
OF <sub>15</sub>	13	18	N <sub>31</sub>	39	38
OF <sub>16</sub>	10	37	N <sub>32</sub>	29	12

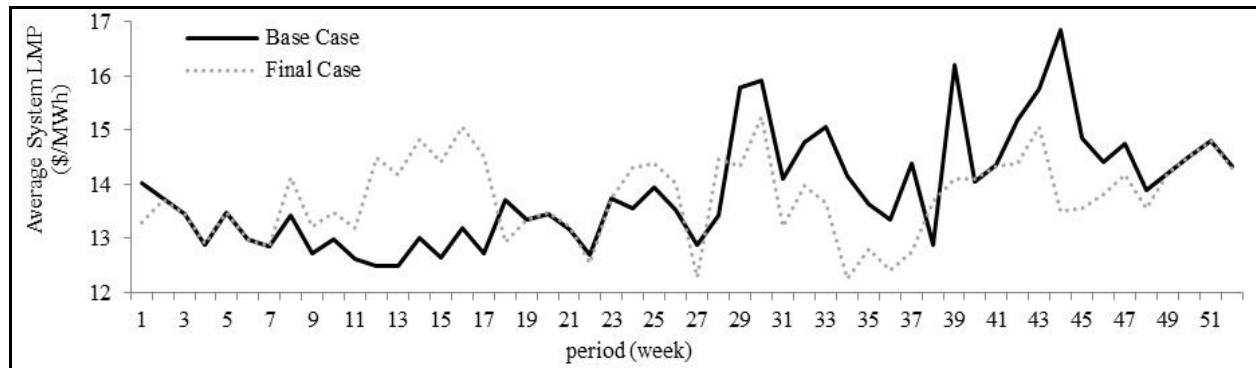

Fig.2. Average system LMP

#### 4. Conclusion

Preventive maintenance scheduling of generating units is emphasized as one of the most important issue in power systems aiming to increase the reliability as well as cost reduction. The problem main purpose is determining the most proper maintenance scheme of the unit in order to safety inspection, while the maintenance as well as operation expenditures are both minimized. In this paper, a new structure is presented based upon MILP formulation which is associated with a cost reduction index (CRI). In the suggested model, CRI is obtained in the pre-generation scheduling which is performed before maintenance scheduling. Indeed, CRI improves the maintenance scheme in order to minimize the operating cost. The proposed model is applied to the standard IEEE-RTS system and the

simulation results justify the effectiveness of the proposed method. It was concluded that utilizing CRI in real system scheduling can be effective, and improves the economy of the power system operation. More research is needed to develop the proposed index, i.e. CRI.

#### References

- [1] S. Perez Canto, "Application of benders' decomposition to power plant preventive maintenance scheduling," *European Journal of Operational Research*, vol. 184, pp. 759-777, 2008.
- [2] G. Rothwell, J. Rust, "A dynamic programming model of U.S. nuclear power plant operations," Feb 1995.
- [3] A. Abiri-Jahromi, M. Fotuhi-Firuzabad, M. Parvania, "Optimized midterm preventive maintenance outage



- scheduling of thermal generating units," IEEE Trans. on Power Sys., vol. 27, no.3, pp. 1354–1365, 2012.
- [4] E. Reihani, A. Sarikhani, M. Davodi, M. Davodi, "Reliability based generator maintenance scheduling using hybrid evolutionary approach," Electrical Power and Energy Sys., vol. 42, pp. 434–439, 2012.
- [5] S.M.H. Hadavi, "Risk-Based, genetic algorithm approach to optimize outage maintenance schedule," Annals of Nuclear Energy, vol. 35, pp. 601–609, 2008.
- [6] A. Volkanovskia, B. Mavkoa, T. Bosevskib, A. Causevskib, M. Cepin, "Genetic algorithm optimization of the maintenance scheduling of generating units in a power system," Reliability Engineering and Sys. Safety, vol. 93, pp. 757–767, 2008.
- [7] G. Samuell, C. Asir Rajan, "A modified genetic approach to long-term generation maintenance scheduling to enhance the reliability of the units," IEEE International Conference on Advances in Engineering, Science and Management, pp. 978–981, 2012.
- [8] S. Baskar, P. Subbarai, M.V.C. Rao, S. Tamilselvi, "Genetic algorithm solution to generator maintenance scheduling with modified genetic operators," Proceedings on IEEE Generation, Transmission & Distribution Conference, pp. 56–60, 2003.
- [9] J.T. Saraiva, M.L. Pereira, V.T. Mendes, J.C. Sousa, "A simulated annealing based approach to solve the generator maintenance scheduling problem," Electric power sys. Research, vol. 81, no. 7, pp. 1283–1291, 2011.
- [10] K.P. Dahal, N. Chakpitak, "Generator maintenance scheduling in power system using metaheuristic based hybrid approaches," Electric power sys. Research, pp. 771–779, 2007.
- [11] D. Nguyen, M. Bagajewicz, "Optimization of Preventive Maintenance Scheduling in Processing Plants," 18th European Symposium on Computer Aided Process Engineering, pp. 319–324, 2008.
- [12] D. Srinivasan, K. Chin Aik, I. Mulyawan Malik, "Generator maintenance scheduling with hybrid evolutionary algorithm," Probabilistic Methods Applied to Power Sys. IEEE, pp. 632–637, 2010.
- [13] M.Y. El-Sharkh, A.A. El-Keib, H. Chen, "A fuzzy evolutionary programming based solution methodology for security constrained generation maintenance scheduling," Electric power Sys. Research, vol. 67, pp. 67–72, 2003.
- [14] El-Amin, I.M., Duffuaa, S.O., Abbas, M.T, "A tabu search algorithm for maintenance scheduling of generating units," Electric Power Sys. Research, vol. 54, no. 2, pp.91–99, 2000.
- [15] W. K. Foong, H.R. Maier, A.R. Simpson, "Power plant maintenance scheduling using ant colony optimization: an improved formulation," Energy Optimization, vol. 40, pp. 309–329, 2008.
- [16] W. K. Foong, "Ant Colony optimization for power plant maintenance scheduling," PhD thesis, university of Adelaide, 2007.
- [17] C.A. Koay, D. Srinivasan, "Particle swarm optimization-based approach for generator maintenance scheduling," Proceedings of IEEE Swarm Intelligence Symposium Conference, pp. 167–173, 2003.
- [18] Y. Yare, G.K. Venayagamoorthy, U.O. Aliyu, "Optimal generator maintenance scheduling using a modified discrete PSO," Generation, Transmission & Distribution, IET, vol. 2, no. 6, pp. 834–846, 2008.
- [19] N. Kumarappan, K. Suresh, "Particle Swarm Optimization based Generation Maintenance scheduling using levelized risk method," IEEE Power sys. technology and Power India conference New Delhi, vol. 1, pp. 1–6, 2008.
- [20] N. M. Tabari, B. Hassanpour, H. Daneshi, R. Sirjani, "A new fuzzy based approach for thermal units maintenance scheduling," Universities Power Engineering Conference, pp. 1–6, 2010.
- [21] روح الامینی، مهدی، رشیدی نژاد، مسعود، "تدارک هم‌زمان انرژی و ذخیره کنترل فرکانس اولیه با در نظر گرفتن محدودیت گرفتگی خطوط"، نشریه مهندسی برق و الکترونیک ایران، سال نهم، شماره دوم، ۱۳۹۱.
- [22] Reliability Test System Task Force of the Application of Probability Methods Subcommittee, "IEEE reliability test system," IEEE Trans. on Power Apparatus and Sys. Vol. 98, no. 6, pp. 2047–2054, 1979.