

Probabilistic Optimal Operation of a Smart Grid Including Wind Power Generator Units

Behrooz Zaker¹

Mohammad Mohammadi²

¹ BSc, School of Electrical & Computer Engineering, Power and Control Engineering Department, Shiraz University, Shiraz, Iran
zaker.behrooz@aut.ac.ir

² Associated Professor, School of Electrical & Computer Engineering, Power and Control Engineering Department, Shiraz University, Shiraz, Iran
m.mohammadi@shirazu.ac.ir

Abstract :

This paper presents a probabilistic optimal power flow (POPF) algorithm considering different uncertainties in a smart grid. Different uncertainties such as variation of nodal load, change in system configuration, measuring errors, forecasting errors, and etc. can be considered in the proposed algorithm. By increasing the penetration of the renewable energies in power systems, it is more essential to consider the stochastic nature of wind power generation units. In this study, probability density function (PDF) of wind speed has been considered as Weibull. The proposed algorithm is based on point estimation method. In order to show the effectiveness of the proposed algorithm it has been applied to IEEE 14-bus test case power system. Simulation results show the effectiveness and precision of the proposed algorithm.

Keywords: Point estimation, Probabilistic optimal power flow, Probability density function, Wind power.

Submission date: 8, Jun, 2012

Conditionally acceptance date: 19, Nov., 2012

Acceptance date: 11, March, 2013

Corresponding author: Mohammad Mohammadi

Corresponding author's address: No.1, Zand St. Power and Control Eng. Dep., Shiraz Uni. Shiraz, Iran.



1. Introduction

Smart grid is a complicated power network that uses bidirectional communications among energy resources, customers, and a central control system, which leads to optimal operation and control of power flow in a power system. Power quality improvements, optimal exploitation of renewable energy resources such as wind power, system self-repairing when failures happen, and opportunity for the customers to manage their electricity usage for minimizing their expenses and so on are some of the advantages of smart grid [1-3].

In recent years, utilization of renewable energy sources such as wind power and photovoltaics has been increased considerably because of some reasons such as environmental concern, increment in fossil fuels prices, etc. Using wind power in shape of wind farms has a high penetration in power systems. Therefore, probabilistic studies are essential to analyze these systems.

The power flow study has been commonly used as an efficient tool in power system expansion planning, real-time control and protection against different kinds of system faults such as short circuit fault. Since economic consideration, is one of the most important aspects in engineering decisions, the optimal power flow has been used instead of power flow due to minimizing the generation costs [18-19].

In the power plants, each generation unit has a specific cost function which shows the relation between generated power and cost in shape of a polynomial as below:

$$C_i = \alpha + \beta.P_i + \gamma.P_i^2 \quad (i = 1, 2, \dots, m) \quad (1)$$

where α , β , and γ are constant coefficients and m is the number of generators in the system.

In a sample system with n generator buses and power demand of P_D , the optimal power flow has been used to minimize the total cost of generation, which equals the summation of each unit cost (C_i) while:

$$P_D = \sum_{i=1}^n P_i \quad (2)$$

In real power systems, because of many uncertainties, such as the variation of loads, the change in system configuration, and measuring or forecasting errors of parameters and input variables, the results of deterministic optimal power flow (OPF) is inaccurate [5]. Therefore, the probabilistic optimal power flow (POPF) is used to consider these uncertainties.

Solving power system load flow using probabilistic methods was first proposed by Borkowska in 1974 [13]. One of the most common methods in probabilistic studies is Monte Carlo (MC) simulation. The main drawback of MC simulation is time consumption. In MC simulation, for each probabilistic variable of the

problem, a vector of numbers with size of N_p is selected according to its probability density function (PDF) using random number generating methods. Then, the deterministic solution is run for each generated random numbers. At last, the answer is obtained by averaging the N_p results. Obviously, the more accuracy requires the increment in N_p .

The conventional MC simulation technique is very time consuming; therefore, other methods such as the first-order second-moment method (FOSMM) [6, 14], the cumulant method (CM) [7, 14], and the two-point estimation (T-PE) method [8, 9] have been used to solve the POPF problem. In the T-PE method, every uncertain variable is replaced with only two deterministic points, which placed on each side of the corresponding mean [12] that enables the use of the deterministic OPF.

Previous literatures have presented different solutions for OPF problem using two point estimation (T-PE) method. In these studies, only normal distribution has been considered for random variables [10], [11].

In this paper, stochastic behavior of demand loads is introduced in the OPF calculation by N-point estimation (N-PE) method and different types of probability distribution are discussed. In the N-PE method, each uncertain demand load is replaced with N_p points. One of the main advantages of the proposed approach is reduced computational time, since only $N.M$ runs of the deterministic OPF are needed for M uncertain variables.

The paper has been organized as follows: An introduction to variable wind speed and wind turbine generation is outlined in Section 2. Section 3 has been allocated to introduce the N-PE method. Section 4 has presented the application of N-PE method to solve the probabilistic optimal power flow (POF) problem. Monte-Carlo (MC) simulation has been discussed in Section 5. Results for the IEEE 14-bus test case have been presented in Section 6 and finally; some conclusions have been derived in the last section.

2. Wind Speed Modeling and Wind Turbine

Since using wind power can reduce the CO₂/NO_x/SO₂ emissions generated by traditional fossil fuel, it is one of the cleanest types among all kinds of renewable energy sources. Besides that, wind power is an economic alternative in the areas with appropriate wind speeds [4].

Probabilistic nature of wind speed led to use probability density functions for it. The most common PDFs which has been used for this purpose is two-parameter Weibull distribution as following:

$$\mu_F = f(\mu_1, \mu_2, \dots, \mu_M) \sum_{j=1}^M \sum_{i=1}^{N_p} p_{j,i}$$

$$+ \sum_{k=1}^{\infty} \sum_{j=1}^M \frac{1}{k!} \frac{\partial^k f}{\partial x_j^k} (\mu_1, \mu_2, \dots, \mu_M) (p_{j,1} \cdot \xi_{j,1}^k + \dots + p_{j,N_p} \cdot \xi_{j,N_p}^k) \sigma_j^k$$
(16)

Make the first $2N_p$ orders of (10) and (16) equivalent, so we will find the $2N_p-1$ required equations for j th variable as follow:

$$p_{j,1} \cdot \xi_{j,1}^i + p_{j,2} \cdot \xi_{j,2}^i + \dots + p_{j,N_p} \cdot \xi_{j,N_p}^i = \lambda_i$$

$$i=1, \dots, 2N_p-1 \quad j=1, 2, \dots, M$$
(17)

At the end we have a set of equation including (15) and (17) in dimension of $2N_p$ with $2N_p$ unknowns including $\{p_{i,1}, p_{i,2}, \dots, p_{i,N_p}, \xi_{i,1}, \xi_{i,2}, \dots, \xi_{i,N_p}\}$ for each variable of the system.

As (17) shows, $2N_p-1$ equations in the system are nonlinear. Therefore, numerical techniques are required to solve this set of equations. In this paper, this set of equations has been solved using FSOLVE command of MATLAB.

4. Application of N-PE Method to Solve POFP

The following flowchart given by Fig. 2 explains how the algorithm is performed:

Step 1: In the OPF problem, the random variables are active power loads (P_D) and reactive power loads (Q_D). These variables which have been characterized by probability density function (PDF) are considered as inputs. Besides that, N_p (number of estimated points) is an input.

Step 2: For the z th random variable the set of equations including (15), (17) has been solved to find unknowns $p_{z,j}, \xi_{z,j}$ ($j=1, 2, \dots, N_p$). After that, $\{x_{z,1}, x_{z,2}, \dots, x_{z,N_p}\}$ have been determined using (13).

Step 3: In this step, x_z has been replaced with $x_{z,j}$ and other random variables are kept at their mean values to use them in deterministic OPF. OPF has been run by means of MATPOWER, using this new value for the z th variable and the mean values for other variables. The results have been saved as below:

$$\theta_{z,1} = h(\mu_1, \mu_2, \dots, x_{z,1}, \dots, \mu_M)$$
(18)

$$\theta_{z,2} = h(\mu_1, \mu_2, \dots, x_{z,2}, \dots, \mu_M)$$

$$\vdots$$
(19)

$$\theta_{z,N_p} = h(\mu_1, \mu_2, \dots, x_{z,N_p}, \dots, \mu_M)$$
(20)

where θ_z is the result of deterministic OPF solution, such as active generated power (P_G) and reactive generated power (Q_G) of the generators of the system.

Step 4: At the end, the final answer has been obtained as below:

$$E(F) = \sum_{i=1}^M [p_{i,1} \cdot \theta_{i,1} + p_{i,2} \cdot \theta_{i,2} + \dots + p_{i,N_p} \cdot \theta_{i,N_p}]$$
(21)

$$VAR(F) = \sum_{i=1}^M \{p_{i,1} \cdot [\theta_{i,1}]^2 + p_{i,2} \cdot [\theta_{i,2}]^2 + \dots + p_{i,N_p} \cdot [\theta_{i,N_p}]^2\}$$

$$- [E(F)]^2$$
(22)

where $E(F)$ and $VAR(F)$ are the mean value and the variance of the specific output results respectively.

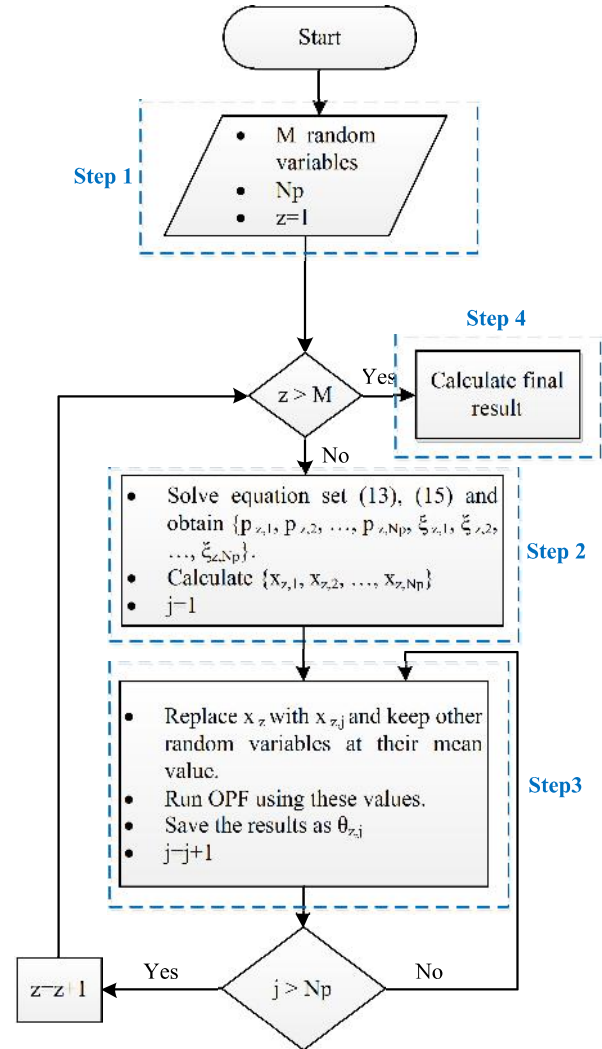

Fig. 2. Flowchart of proposed algorithm

5. Simulation Results

In order to demonstrate the effectiveness of the proposed algorithm, it has been applied to IEEE 14-Bus test case power system [17]. This system contains 14 buses, two generators, three synchronous condensers (bus 3, 6, and 8), 10 load points, and 20 branches. The single line diagram of the system has been depicted in Fig. 3.

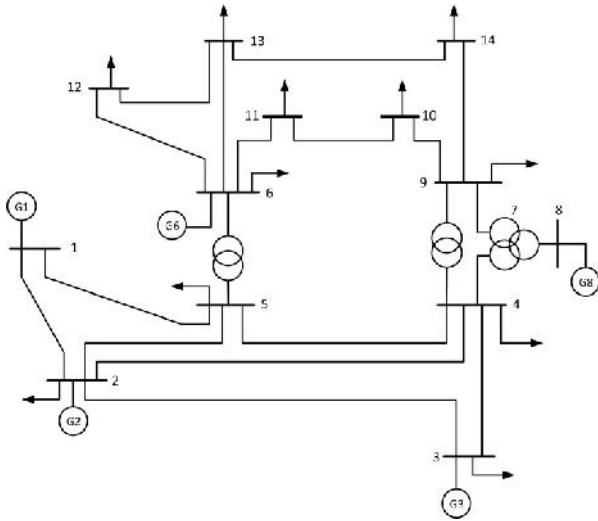

Fig. 3. IEEE 14-Bus system

The cost function of each generator has been considered as (1) and the value of α , β , and γ which are constant coefficients has been presented in Table 1. In order to run OPF, some constraints such as maximum and minimum active and reactive power have been considered for each generation unit. These constraints have given in Table 2. Bus voltages could vary from 0.94 to 1.06 per unit. For all the transmission lines, long term rating has been considered equal to 9900 MVA.

Table 1. Cost function coefficients

Generator	α	β	γ
G ₁	0	20	0.04303
G ₂	0	20	0.2500
G ₃	0	40	0.0100
G ₄	0	40	0.0100
G ₅	0	40	0.0100

Table 2. Generators constraints (MW & MVar)

Generator	Q _{max}	Q _{min}	P _{max}	P _{min}
G ₁	10	0	332.4	0
G ₂	50	-40	140	0
G ₃	40	0	100	0
G ₄	24	-6	100	0
G ₅	24	-6	100	0

Three different types of PDF have been considered for load points in this study; Normal, Uniform, and Weibull. A wind turbine with specifications which have been mentioned in Section 2 has been considered on Bus#11. Characteristic parameters of each PDF have been given in Table 3. Probability density functions of loads have been listed in Table 4.

Table 3. Characteristic parameters

PDF Type	First Parameter	Second Parameter
Normal	Mean (μ)	Variance (σ^2)
Uniform	Lower Bound (a)	Upper Bound (b)
Weibull	Scale Parameter (a)	Shape Parameter (b)

Optimal power flow has been run in this system using Monte Carlo (MC) simulation, Two Point Estimation (T-PE) method, and Three Point Estimation method. Final outputs are mean value and standard deviation of active and reactive generated power of each generator and synchronous condenser of the system.

The stochastic OPF has been run using MC simulation with 1500 simulations, T-PE method, and Three Point Estimation method. The results of these simulations have been given in Table 5, Table 6, and Table 7 respectively. It can be seen that the results are very close to each other, in spite of large differences in required calculation time for each method. The required calculation time for MC simulation, T-PE method, and Three Point Estimation method have been compared in Table 8.

Table 4. Probability density functions of loads

Bus Number & Load Type	Distribution Type	First Parameter(MW)	Second Parameter(MW)	
2	P	Uniform	20	23.4
	Q	Uniform	10	15.4
3	P	Uniform	90	98.4
	Q	Uniform	16	22
4	P	Normal	47.8	2.25
	Q	Normal	-3.9	1
5	P	Normal	7.6	1.12
	Q	Normal	1.6	1
6	P	Weibull	11.44	25
	Q	Weibull	8.17	5
9	P	Normal	29.5	1.5
	Q	Normal	16.6	0.85
10	P	Weibull	9.56	8
	Q	Weibull	6.32	5
12	P	Uniform	5	7.2
	Q	Uniform	1	2.2
13	P	Normal	13.5	0.7
	Q	Normal	5.8	1.3
14	P	Uniform	13	16.8
	Q	Uniform	3	7



Table 5. Results of MC simulation (1500 simulations)

Gen. & Cond. Bus #	P_G (Mean Value)	P_G (Standard Deviation)	Q_G (Mean Value)	Q_G (Standard Deviation)
1	193.9048	0.4429	0.2451	0.00085
2	36.6420	0.0852	23.4923	1.8523
3	27.1500	1.9669	24.0864	1.7263
6	0.3456	0.00077	9.8029	2.3874
8	6.2332	2.3037	8.0012	0.5301

Table 6. Results of T-PE method

Gen. & Cond. Bus #	P_G (Mean Value)	P_G (Standard Deviation)	Q_G (Mean Value)	Q_G (Standard Deviation)
1	193.3617	1.4375	0.2376	0.00084
2	36.5462	0.2647	23.9595	1.8354
3	26.9418	1.9026	24.3729	1.7552
6	0.2786	1.8593	11.2044	2.4781
8	6.1192	2.0130	8.2872	0.5505

Table 7. Results of Three Point Estimation method

Gen. & Cond. Bus #	P_G (Mean Value)	P_G (Standard Deviation)	Q_G (Mean Value)	Q_G (Standard Deviation)
1	193.6502	6.4624	0.00069	0.00015
2	36.3789	1.7881	23.3024	2.1667
3	26.4201	2.3422	23.9568	2.1116
6	0.2704	0.00013	12.1941	2.5390
8	5.9960	1.9214	8.4142	0.6794

Table 8. MCS, T-PEM, and 3-PEM Comparison

Simulation Type	Calculation Time (s)
Monte Carlo	239.91
2-Point Estimation	9.45
3-Point Estimation	38.74

The relative errors of active generated powers of generators between MC simulation, T-PE method, and Three Point Estimation method have been given in Table 7. There are two considerable errors in Table 9, 19.38% and 21.76%.

It is because of the errors in numerical solution of a nonlinear set of equations, including (17). However, the errors are acceptable.

Table 9. Relative errors of P_G

Bus Number	MCS , 2-PEM	MCS , 3-PEM
1	0.2800 %	0.1313 %
2	0.2600 %	0.7180 %
3	0.7685 %	0.0408 %
6	19.3800 %	21.7590 %
8	1.8289 %	3.8054 %

6. Conclusion

This paper presents N-Point estimation method to handle stochastic smart grid's problems such as, probabilistic optimal power flow in presence of wind generation. The proposed method has been tested on the IEEE 14-bus system with an additional wind turbine, in which the Monte Carlo method has been used to compare the results with the two point and three point estimation method. Results confirm very good performance of T-PE method in terms of the accuracy and calculation time. However, results show a few considerable errors in T-PE method and Three Point Estimation method; it is because of the error in numeric solution of a nonlinear set of equations in dimension of six. More advanced and accurate techniques of numeric solution which requires additional investigations can decrease these errors.

References

- [1] E. Santacana, G. Rackliffe, Le Tang and Xiaoming Feng, "Getting Smart", Power and Energy Magazine, IEEE, Vol. 8, No. 2, March-April 2010, pp.41-48.
- [2] K. Moslehi and R. Kumar, "A Reliability Perspective of the Smart Grid", Smart Grid, IEEE Transactions on, Vol.1, No.1, June 2010, pp. 57-64.
- [3] A. Ipakchi and F. Albuayeh, "Grid of the future", Power and Energy Magazine, IEEE, Vol.7, No.2, March-April 2009, pp.52-62.
- [4] Chen Wang, Libao Shi, Liangzhong Yao, Liming Wang, Yixin Ni, and Masoud Bazargan, "Modelling Analysis in Power System Small Signal Stability Considering Uncertainty of Wind Generation," Power and Energy Society General Meeting, 2010 IEEE, 2010, pp. 1-7.
- [5] Xue Li, Yuzeng Li, and Shaohua Zhang, "Analysis of Probabilistic Optimal Power Flow Taking Account of the Variation of Load Power," *IEEE Trans. Power Syst.*, vol. 23, no. 3, pp. 992-999, AUGUST 2008.
- [6] M. Madrigal, K. Ponnambalam, and V. H. Quintana, "Probabilistic optimal power flow", in *Proc. IEEE Can. Conf. Electrical and Computer Engineering*, Waterloo, ON, Canada, May 1998, pp. 385-388.
- [7] A. Schellenberg, W. Rosehart, and J. Aguado, "Cumulant based probabilistic optimal power flow (P-OPF) with Gaussian and gamma distributions," *IEEE Trans. Power Syst.*, vol. 20, no. 2, pp. 773-781, MAY 2005.

- [8] G. Verbić and C. A. Cañizares, "Probabilistic optimal power flow in electricity markets based on a two-point estimate method," *IEEE Trans. Power Syst.*, vol. 21, no. 4, pp. 1883–1893, Nov. 2006.
- [9] C.-L. Su, "Probabilistic load-flow computation using point estimate method," *IEEE Trans. Power Syst.*, vol. 20, no. 4, pp. 1843–1851, Nov. 2005.
- [10] Juan. M. Morales and Juan. Pérez-Ruiz, "Point Estimate Schemes to Solve the Probabilistic Power Flow," *IEEE Trans. Power Syst.*, vol. 22, no. 4, Nov. 2007.
- [11] X. Liu and J. Zhong, "Point Estimate Method for Probabilistic Optimal Power Flow with Wind Generation," *The International Conference on Electrical Engineering*, 2009.
- [12] E. Rosenblueth, "Two-point Estimates In Probabilities," *Appl. Math. Modelling*, vol. 5, Oct. 1981.
- [13] B. Borkowska, "Probabilistic load flow," *IEEE Trans. Power App. Syst.*, vol. PAS-93, pp. 752–759, Apr. 1974.
- [14] A. Schellenberg, W. Rosehart, and J. Aguado, "Cumulant based probabilistic optimal power flow (P-OPF)," in *Proc. Int. Conf. Probabilistic Methods Applied Power Systems*, Sep. 2004, pp. 506–511.
- [15] P. Ramirez, J. A. Carta, "Influence of the data sampling interval in the estimation of the parameter of the Weibull wind speed probability distribution: a case study," *Energy Conv. Manag., Elsevier*, vol. 46, pp. 2419–2438, 2005.
- [16] T. Ackerman, "Wind Power in Power Systems," Wiley, 2005.
- [17] R. Christie, UW Power System Test Case Archive, Available:
<http://www.ee.washington.edu/research/pstca/>.

- [۱۸] سیدحمید فتحی، مرتضی محمدی اردهالی، محمدعلی فتاحی اردکانی "تعیین نقطه کاری بهینه در سیستم تولید همزمان انرژی الکتریکی و گرمایی به همراه مخزن ذخیره گرمایی با استفاده از الگوریتم ژنتیک"، *نشریه مهندسی برق و الکترونیک ایران*، جلد ۶، شماره ۱، بهار و تابستان ۱۳۸۸.
- [۱۹] محمود جورابیان، احسان افضلان، "حل مسئله پخش بار بهینه در شرایط نرمال و اضطراری با استفاده از الگوریتم ترکیبی گروه ذرات و نلدر مید (PSO-NM)"، *نشریه مهندسی برق و الکترونیک ایران*، جلد ۱۰، شماره ۱، بهار و تابستان ۱۳۹۴.

