

# Series Resonance Based Fault Current Limiter with Controlling The Point of Common Coupling Voltage

Hamid Radmanesh<sup>1</sup> Amir Heidary<sup>2</sup> Seyed Hamid Fathi<sup>3</sup> G.B. Gharehpetian<sup>4</sup>

<sup>1</sup> Assistant Professor, Electrical Engineering Department, Shahid Sattari Aeronautical University of Science and Technology, Tehran, Iran  
[hamid.radmanesh@aut.ac.ir](mailto:hamid.radmanesh@aut.ac.ir)

<sup>2</sup> B.Sc., Electrical Engineering Department, Amirkabir University of Technology (Tehran Polytechnic), Tehran, Iran  
[amir.powersys@gmail.com](mailto:amir.powersys@gmail.com)

<sup>3</sup> Professor, Electrical Engineering Department, Amirkabir University of Technology (Tehran Polytechnic), Tehran, Iran  
[fathi@aut.ac.ir](mailto:fathi@aut.ac.ir)

<sup>4</sup> Professor, Electrical Engineering Department, Amirkabir University of Technology (Tehran Polytechnic), Tehran, Iran  
[grptian@aut.ac.ir](mailto:grptian@aut.ac.ir)

## Abstract:

This paper proposes a novel Fault Current Limiter (FCL) for the application on distribution networks to control voltage sags at the Point of Common Coupling (PCC) during faults. This new FCL is based on series resonance including resonance transformer and series capacitor. So, by proper design of the series resonance LC tank, the fault current is limited to an acceptable level. The FCL operation is simulated using MATLAB software. In order to confirm the simulation results, a prototype structure is built and its measurement results are in agreement with the simulation results. The simulated and experimental results show that it is feasible to develop the FCL with low cost and high reliability.

**Key words:** Fault Current Limiter (FCL), Resonance Transformer, Power Quality, Point of Common Coupling (PCC)

---

**Submission date:** 30, July, 2015

**Conditionally Acceptance date:** 9, March, 2016

**Acceptance date:** 9, July, 2016

**Corresponding author :** Hamid Radmanesh

**Corresponding author's address:** Electrical Engineering Department, Shahid Sattari Aeronautical University of Science and Technology, Tehran, Iran

# 1. INTRODUCTION

The fault current in the power system tends to increase over time for different reasons; e.g., electric power demand increase (load growth) and subsequent increase in generation, new parallel conducting paths, new interconnections within the grid and new distributed generation units. The fault currents, flowing from the sources to the fault, lead to high dynamical and thermal stresses being imposed on equipments like overhead lines, cables, transformers and switchgears [1]. Therefore, there is a considerable interest in devices, which are capable of limiting ault currents. The simplest way to limit the short-circuit current would be the use of an impedance. The drawback of this solution is that it also obviously influences the system during normal operation, i.e, it results in considerable voltage drops at high load currents [2] and [3]. A Fault Current Limiter (FCL) can limit the fault current passing through it within the first half cycle. In normal operation mode, the impedance of the FCL is much less, while in the current limiting mode, the impedance is higher than the impedance of the network [4]. The concept of the FCL is to limit the fault current before its first peak, although the response speed is of greatest importance. Also, an ideal FCL should have the following characteristics: low impedance at normal operation, very short recovery time, large impedance in fault conditions, fault current limitation before the first peak, proper response to any probable fault level, high reliability and finally low cost. Since the 1970s, several types of scheme have been applied in power systems, such as the fuse with fault-current limitation, Superconducting Fault Current Limiters (SFCLs) [5], hybrid resistive SFCLs [6], saturable core SFCLs [7], shielded-core SFCLs [8], solid-state FCLs [9], and bridge type [10]. In recent years, power electronic based FCLs have been proposed in [11] and [12], which has the features of a series compensation under normal conditions. The influence of the FCL on short-circuits current level of substation circuit breaker and its transient recovery voltage has been studied in [13]. The necessity and procedure for the application of FCL and bus sectionalizing system have been discussed in [14]. A transformer inrush current limiter based on DC reactor has been studied in [15]. The bridge-type FCLs with reduced number of controlled devices have been given in [16] and [17]. In [18] the fault current application on power network with wind turbine generation is discussed. FCL application for restoring directional over-current relay coordination has been presented in [19]. Also a DC reactor type FCL has been used in [20] for restoring PCC voltage and controlling the fault current to an acceptable level. In addition, the FCL application for improving transient recovery voltage of circuit breaker is proposed in [21]. In current paper, the suggested FCL operation is compared with FCL structure presented in [22]. This reference is carefully investigated and its problems are solved by suggesting the new FCL structure. This paper has been organized as follows: In section II, the proposed distribution network configuration including FCL and its operation principles has been presented. The analysis of

the proposed FCL has been developed in section III, and Section IV discusses the simulation results and section V includes experimental results of the built prototype. Finally, last section gives the conclusion and highlighted merits of the proposed FCL.

# 2. ELECTRICAL NETWORK CONFIGURATION

Fig. 1 shows two feeders electrical network where in the parallel feeder single line to ground fault is occurred. The downstream fault of the faulty feeders could result in large fault current flow, which not only might damage the series equipments but also can cause voltage drop at Point of Common Coupling (PCC). The voltage drop in the PCC can affect other loads on parallel feeders connected to it. To prevent the voltage sag at PCC, the suggested FCL is connected in series with the faulty feeder as shown in Fig. 1. The primary side of the transformer is connected in series with the capacitor and transmission line. Also, the secondary side of the transformer is switched by two anti-parallel semiconductor switches (IGBTs) to change the impedance of the transformer. The main control component is two anti-parallel fast-closing IGBTs connected in parallel with the secondary side of the transformer. When a fault occurs, the IGBTs turn-on and bypass the transformer secondary side, and fault current is limited by the capacitor impedance.

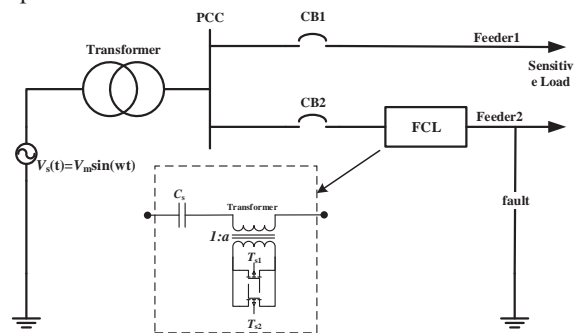


Fig. 1. Electrical system with loads connected to PCC through parallel feeders

## 2.1. FCL Normal Operation Mode

Fig. 2 shows FCL configuration during normal operation mode. In this case, the impedance of the suggested FCL includes series capacitor and the primary winding of the series transformer. Because of the series resonance structure of the FCL, the series capacitor and primary winding of the transformer have resonance frequency the same as the power system frequency, while the secondary side of the transformer is open and the total impedance of the FCL is near zero. So, the transformer works as an AC reactor and the impedance of the FCL, i.e.,  $C_s$  and series transformer is near to zero. In order to

decrease the flux linkage of the transformer and voltage of the secondary, this equipment is designed by lowest turn of winding up to possible value. For three phase electrical system, there are three FCLs, installed in each phase of the transmission line for controlling the overcurrent of each phase separately. In this FCL structure,  $C_s$  is series capacitors and transformer is represented by  $T_1$  and connected to the transmission line. In addition, the IGBTs,  $T_s$ , are connected in series with the secondary of transformer. A significant advantage of the suggested FCL technology is its ability to remain virtually invisible to the grid under normal operation and introducing negligible impedance in the system until a fault event occurs.

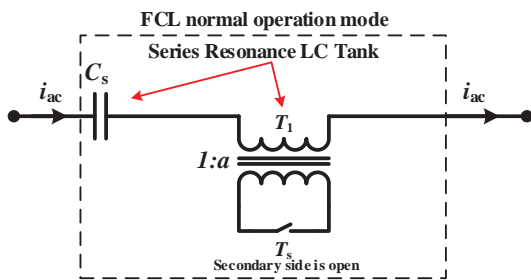


Fig. 2. FCL configuration during normal operation mode

## 2.2. FCL Fault Operation Mode

Fig. 3 shows the FCL configuration during the fault current limiting mode. When the fault occurs, the IGBTs are turned ON and close the secondary side of the transformer as shown in Fig. 3. In this case, the impedance of the resonant LC tank changes to the series capacitor impedance and its impedance decreases the fault current to an acceptable level. Also, the series capacitor impedance returns the PCC voltage and fixes it to an acceptable level.

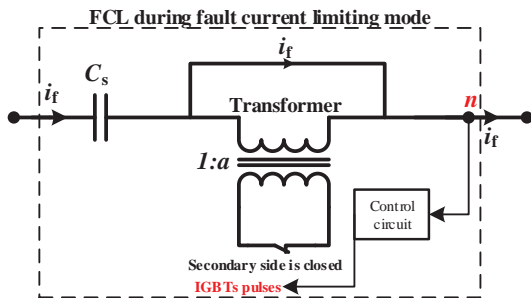


Fig. 3. FCL configuration during fault operation mode

In addition, once the limiting action is no longer needed, the FCL quickly return to its normal low impedance state.

## 3. CIRCUIT ANALYSIS

The proposed FCL operates in two modes. In the first mode, fault current magnitude is still less than a specified current level ( $I_L$ ) and in the second mode, the fault current magnitude has exceeded the  $I_L$ . In the first mode, IGBTs are in OFF state and there is no voltage drop on FCL components. During the first state, the series LC tank is in resonance condition and the equivalent circuit of the electrical network is a RL circuit where the line current is given by the equation (1).

$$V_m \sin(\omega t) = L \frac{di_L(t)}{dt} + Ri_L(t) \quad (1)$$

The initial condition for equations (1) is  $i_L(0)=I_0$ , where,  $R$  and  $L$  in equation (1) includes source, line, and load resistance and inductance. In this case the system is in steady state condition so transient response is removed. By solving the equation (1), the equation (2) can be derived.

$$i_L(t) = \frac{V_m}{\sqrt{R^2 + \omega^2 L^2}} \sin\left(\omega t - \tan^{-1} \frac{\omega L}{R}\right) \quad (2)$$

In fault condition, the line current amplitude is increased rapidly and passes from the specified current level ( $I_L$ ). In this case, the control circuit turns-on the IGBTs and the line current is decreased via the capacitor impedance. Furthermore, the equivalent circuit of the electrical network in fault current limiting mode is a RLC circuit and by applying Kirchhoff's circuit laws to this circuit, the equation (3) can be derived for describe the fault current limiting mode.

$$V_m \sin(\omega t) = L \frac{di_L(t)}{dt} + Ri_L(t) + V_C(t) \quad (3)$$

where, the values of  $L$  and  $R$  includes line and source inductance and resistance,  $V_C(t)$  is series capacitor voltage and the electrical load is short circuited and is not considered. The initial condition for equations (3) is  $i_L(0)=I_1$ .

Also, the series transformer is bypassed via IGBTs and the electrical network source voltage is assumed sinusoidal, with  $V_m$  and  $\omega$  as the effective voltage and angular frequency, respectively. By solving the equation (3) for fault case, we have:

$$V_C(t) = e^{-\alpha t} (A_1 \cos \beta t + A_2 \sin \beta t) + \frac{V_m}{\sqrt{(1-LC\omega^2)^2 + (RC\omega)^2}} \sin\left(\omega t - \tan^{-1}\left(\frac{RC\omega}{(1-LC\omega^2)}\right)\right) \quad (4)$$

where,  $A_1$  and  $A_2$  can be obtained using initial conditions of the capacitor and inductor and for  $i_L(t)$  we have:

$$i_L(t) = C(e^{-\alpha t} (A_1 \cos \beta t + A_2 \sin \beta t))' + \frac{V_m}{\sqrt{(1-LC\omega^2)^2 + (RC\omega)^2}} \omega \cos\left(\omega t - \tan^{-1}\left(\frac{RC\omega}{(1-LC\omega^2)}\right)\right) \quad (5)$$

where,  $\alpha = \frac{R}{2L}$ ,  $\omega_0 = \frac{1}{\sqrt{LC}}$  and  $\beta = \sqrt{\alpha^2 - \omega_0^2}$ .

The initial condition for  $L$  is  $i_L(0^-) = i_L(0^+) = I_0$  and for  $C$  is  $V_C(0^-) = V_C(0^+) = V_0$ . Equations (4) and (5) are composed of exponential and sinusoidal parts. The exponential part causes a transient in the line current as shown in the simulation results and duration of this transient depends on the FCL time constant.

#### 4. FCL CONTROL STRATEGY

The fault detector circuit which is connected to node "n" (Fig. 3) is shown in Fig. 4. It consists of one rectifier bridge, a capacitor and a resistive voltage divider. In normal operation mode, the capacitor voltage has a marginal value as compared with  $V_{ref}$  and pulse generator output is zero. So, there are no connected power electronic switches (IGBTs) and FCL voltage drop is near zero. During fault, the voltage of PCC and the voltage of the downstream buses decrease suddenly. In this case, the fault detector circuit detects the line voltage drop by comparing capacitor voltage with  $V_{ref}$  and turns-on the IGBTs.

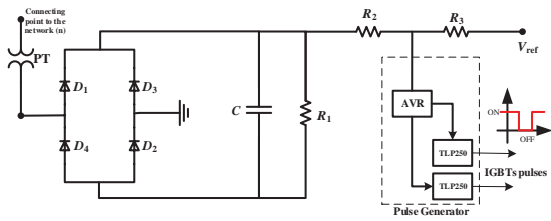


Fig. 4. Control circuit topology of the suggested FCL

#### 5. SIMULATION RESULTS

In this section, the system shown in Fig. 1, is used for simulations. The system parameters are listed in Table (1). The proposed system including FCL is simulated for normal and faulty operation modes. The fault is single phase to ground fault. Also, the system source is solidly grounded.

Fig. 5 shows the line current during normal and fault operation modes while there is no connected FCL in the line. As shown here, the amplitude of the fault current reaches to 5kA.

After fault inception, the FCL inserts in the line and fault current decreases to an acceptable level as shown in Fig. 6. In this case, the series capacitor impedance limits the fault current to 200A. In this application, FCL can successfully control the fault current and limits the transient

overvoltage.

Table.1.  
DISTRIBUTION SYSTEM PARAMETERS

Parameters	Value	Description
$V_s$	20kV	Source Voltage (RMS)
$f$	Frequency	50Hz
$r_f$	Fault Resistance	0.001 $\Omega$
$L_f$	Fault Inductance	0H
$C_s$	56uF	Series Capacitor
$L_p$	2mH	Primary Linkage Inductance of Transformer
$L_m$	0.18H	Magnetization Inductance of Transformer
$L_t$	2mH	Secondary Linkage Inductance of Transformer
$R_p$	2 $\Omega$	Primary Resistance of Transformer
$R_t$	2 $\Omega$	Secondary Resistance of Transformer
$n_1$	300	Primary Turn Ratio
$n_2$	30	Secondary Turn Ratio
Distribution feeders data	Feeder F1	$j 0.314 \Omega$
	Feeder F2	$j 0.157 \Omega$
Load data	Sensitive Load	$10+j15.7 \Omega$
	Load of F2	$15+j31.4 \Omega$

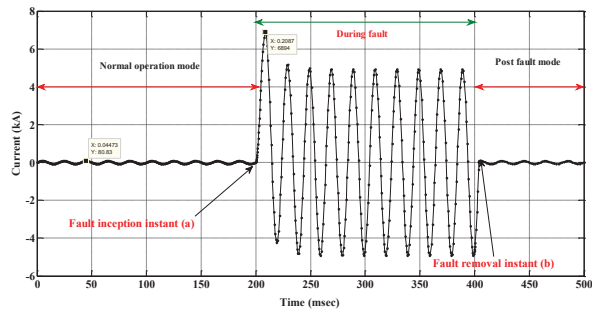
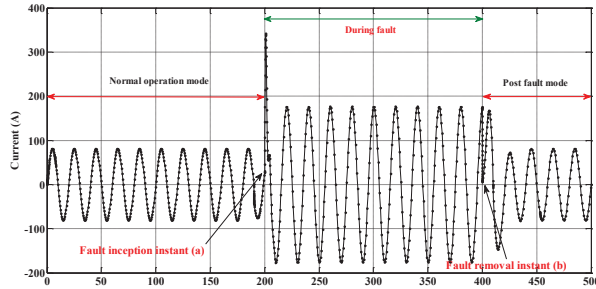
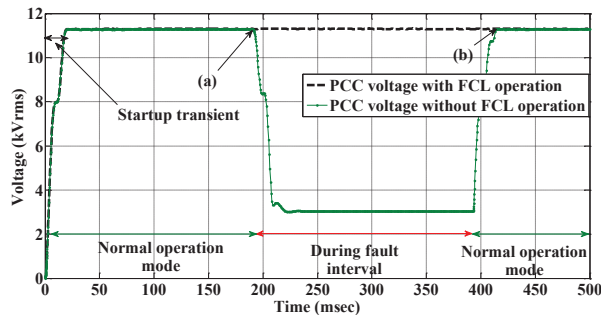


Fig. 5. Line current of the network during normal and fault operation modes without connected FCL

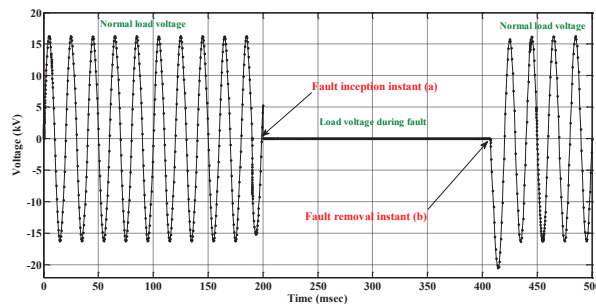


**Fig. 6. Line current during normal and fault operation modes while FCL is connected in series with the transmission line**

Fig. 7 shows the simulated PCC voltage during normal and fault operation modes. In this figure, the fault is occurred at  $t=200ms$  and FCL is operated in this instant. The simulation results show the PCC voltage with and without FCL operation. As shown in Fig. 7, FCL can successfully fix the PCC voltage to an acceptable level so there is no severe voltage sag during the fault.

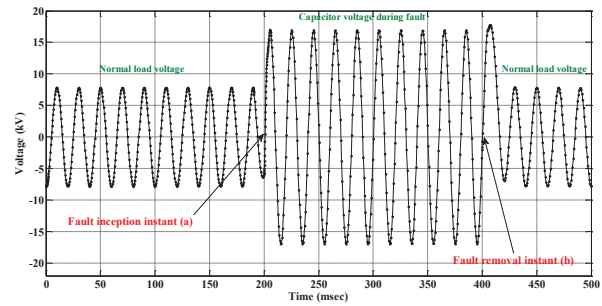


**Fig. 7. PCC voltage during normal and fault operation modes with and without FCL application**



**Fig. 8. Load voltage during normal and fault operation modes**

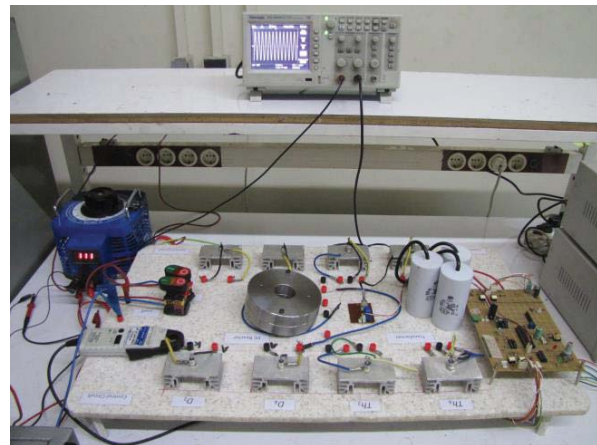
After fault occurrence, the voltage of the load decreases to zero and the IGBTs are in on state, so the voltage of the secondary winding of the transformer is near zero. In this case, the capacitor voltage rises and its impedance limits the fault current. Figs. 8 and 9 show the load and capacitor voltage during normal and fault operation modes, respectively.



**Fig. 9. Series capacitor voltage drop during normal and fault operation modes**

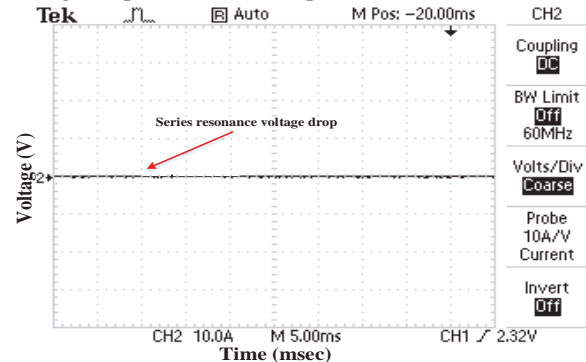
## 6. EXPERIMENTAL RESULTS

To verify the simulation results, the FCL operation is examined using laboratory prototype as shown in Fig. 10. This setup is built using Fig.1.



**Fig. 10. FCL laboratory test setup**

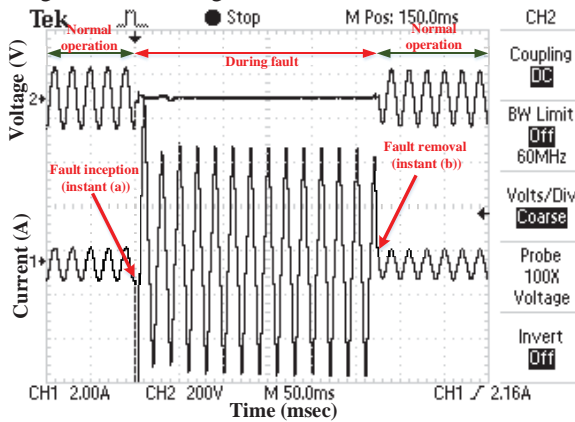
Fig. 11 shows voltage drop on the series resonance LC tank during normal operation mode. In this case the voltage drop on the FCL components is near zero.



**Fig. 11. Voltage drop on the series resonance LC tank during normal operation mode ( $V=220V_{rms}$ , voltage/division = 10V with probe X10 for CH2)**

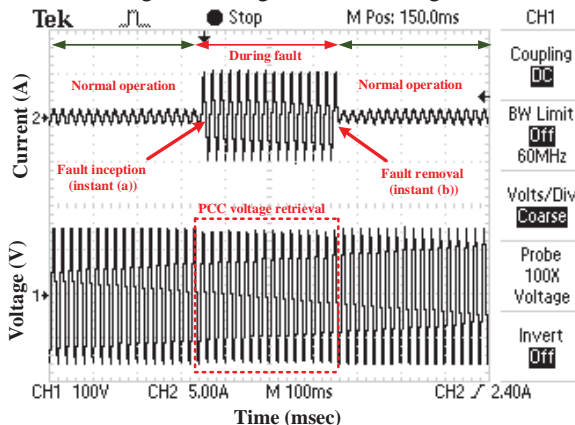


Fig. 12 shows the line current and load voltage during normal and fault operation modes. The FCL can successfully control the fault current and can decrease its amplitude to an acceptable level. In this figure, fault is occurred at instant (a) and is cleared at instant (b). During fault, the IGBTs are turned ON and bypass the series transformer. Delay in FCL operation cause to increase the first peak of the fault current but the FCL operation decreases its amplitude successfully. Fig. 12 is in agreement with Figs. 6 and 8.



**Fig. 12. Line current and load voltage during normal and fault operation modes while FCL is connected in series with the line ( $V=220V_{rms}$ , voltage/division = 2V with probe X100 for CH2 and current/division = 2A with probe X1 for CH1)**

Fig. 13 shows PCC voltage and line current during normal and fault operation modes. As shown in this figure, the quality of PCC voltage during fault is acceptable because FCL successfully fixes it to the normal value and system can work under safe operation conditions. Fig. 13 is in agreement with Fig. 7.



**Fig 13. Voltage of PCC and line current during normal and fault operation modes in the case of FCL operation ( $V=220V_{rms}$ , voltage/division = 1V with probe X100 for CH1 and current/division = 5A with probe X1 for CH1)**

The advantages of the proposed FCL over the FCL in [22] are described as follows:

The suggested FCL effectiveness is verified by

simulations and measurements. It is shown that the suggested FCL has more advantages include lower cost and higher reliability in comparison with FCL in [22]. It can improve the system stability by its fast response after fault occurrence and series compensation after fault clearing. System studies show that the series resonance type FCL can not only limit the fault current to an acceptable value, but also can mitigate the voltage sag.

## 7. CONCLUSIONS

In this paper, a new FCL structure has been studied. Comparing the FCL with other works, the proposed FCL uses series capacitor to restrain the PCC voltage and controlling the fault current amplitude with high impedance. Its advantages include simpler operation, less power losses in the steady state and very fast response to fault current limitation. Also, the configuration of the FCL is simple and reliable. The proposed FCL not only restrains the PCC voltage drop but also limits the fault current when a fault occurs at the load side. The time delay of this FCL operation is very low, the fault detection circuit delay is less than 1ms. So, FCL can limit the fault current before its first peak rising. The simulation results have been compared with the experimental results. The good agreement of simulation and measurement results verifies the effectiveness the proposed FCL. Furthermore, it can also reduce the interrupting rating in the circuit breaker.

## REFERENCES:

- [1] Wenyong Guo; Liye Xiao; Shaotao Dai; Zhifeng Zhang; Tao Ma; Yuanhe Li; Xi Xu, "Multicell Fault Current Limiter," IEEE Transactions on Industrial Electronics, vol.61, no.4, pp.2071-2080, 2014.
- [2] Woo-Cheol Lee, Taeck-Kie Lee, and Dong-Seok Hyun, "Performance Analysis of a Three-Phase Parallel Active Power Filter which Compensates PCC Voltage and the Unbalanced Loads," JPE, vol. 1, no. 1, pp.9-18, 2001.
- [3] Chen, Y.; Liu, X.; Sheng, J.; Cai, L.; Jin, Z.; Gu, J.; An, Z.; Yang, X.; Hong, Z., "Design and Application of a Superconducting Fault Current Limiter in DC Systems," IEEE Transactions on Applied Superconductivity, vol.24, no.3, pp.1-5, 2014.
- [4] Blair, S.M.; Booth, C.D.; Burt, G.M.; Bright, C.G., "Application of Multiple Resistive Superconducting Fault-Current Limiters for Fast Fault Detection in Highly Interconnected Distribution Systems," IEEE Transactions on Power Delivery, vol.28, no.2, pp.1120-1127, 2013.
- [5] Hong, Z.; Sheng, J.; Yao, L.; Gu, J.; Jin, Z., "The Structure, Performance and Recovery Time of a 10 kV Resistive Type Superconducting Fault Current Limiter," IEEE Transactions on Applied Superconductivity, vol.23, no.3, pp.5601304-5601304, 2013.
- [6] Lee, B.W.; Rhee, S.B., "Test Requirements and Performance Evaluation for Both Resistive and Inductive Superconducting Fault Current Limiters for 22.9 kV

- Electric Distribution Network in Korea," *IEEE Transactions on Applied Superconductivity*, vol.20, no.3, pp.1114-1117, 2010.
- [7] Abramovitz, A.; Smedley, K.M.; De la Rosa, F.; Moriconi, F., "Prototyping and Testing of a 15 kV/1.2 kA Saturable Core HTS Fault Current Limiter," *IEEE Transactions on Power Delivery*, vol.28, no.3, pp.1271-1279, 2013.
- [8] Ennis, M.G.; Tobin, T.J.; Cha, Y.S.; Hull, J.R., "Fault current limiter-predominantly resistive behavior of a BSCCO-shielded-core reactor," *IEEE Transactions on Applied Superconductivity*, vol.11, no.1, pp.2050-2053, 2001.
- [9] Naderi, S.B.; Jafari, M.; Tarafdar Hagh, M., "Parallel-Resonance-Type Fault Current Limiter," *IEEE Transactions on Industrial Electronics*, vol.60, no.7, pp.2538-2546, 2013.
- [10] Seyed Majid Madani, Mehrdad Rostami, G.B.Gharehpetian and Reza Hagh Maram, "Improved Bridge Type Inrush Current Limiter for Primary Grounded Transformers", *Electric Power Systems Research (EPSR)*, Vol. 95, No. 2, pp. 1-8, February 2013.
- [11] Wanmin Fei; Yanli Zhang; Zhengyu Lu, "Novel Bridge-Type FCL Based on Self-Turnoff Devices for Three-Phase Power Systems," *IEEE Transactions on Power Delivery*, vol.23, no.4, pp.2068-2078, 2008.
- [12] Hamid Javadi, Fault current limiter using series impedance combined with bus sectionalizing circuit breaker, *International Journal of Electrical Power & Energy Systems*, vol. 33, Issue 3, pp. 731-736, 2011.
- [13] Hongshun Liu; Qingmin Li; Liang Zou; Wah Hoon Siew, "Impact of the Inductive FCL on the Interrupting Characteristics of High-Voltage CBs During Out-of-Phase Faults," *IEEE Transactions on Power Delivery*, vol.24, no.4, pp.2177-2185, 2009.
- [14] Jong-young Park; Seung-Ryul Lee; Jae-young Yoon, "Application of bus-tie HTS-FCL on 154kV buses in the Korean Power System," *Asia and Pacific Transmission & Distribution Conference & Exposition*, pp.1-4, 26-30, 2009.
- [15] Seyed Majid Madani, Mehrdad Rostami, G.B.Gharehpetian and Reza Hagh Maram, "Inrush Current Limiter Based on Three Phase Diode Bridge for Y-yg Transformers", *IET Electric Power Applications*, Vol. 6, Issue 6, pp. 345 – 352, Nov. 2012.
- [16] Wanmin Fei; Yanli Zhang, "A novel IGCT-based Half-controlled Bridge Type Fault Current Limiter," *Power Electronics and Motion Control Conference, 2006. IPEMC 2006. CES/IEEE 5th International*, vol.2, no., pp.1-5, 2006.
- [17] Hagh, M.T.; Abapour, M., "Nonsuperconducting Fault Current Limiter with Controlling the Magnitudes of Fault Currents," *IEEE Transactions on Power Electronics*, vol.24, no.3, pp.613-619, 2009.
- [18] Fereidouni, A.R.; Vahidi, B.; Mehr, T.H., "The Impact of Solid State Fault Current Limiter on Power Network with Wind-Turbine Power Generation," *IEEE Transactions on Smart Grid*, vol.4, no.2, pp.1188-1196, 2013.
- [19] Hamid Javadi, S.M. Ali Mousavi, Mojtaba Khederzadeh, A novel approach to increase FCL application in preservation of over-current relays coordination in presence of asynchronous DGs, *International Journal of Electrical Power & Energy Systems*, Vol. 44, Issue 1, pp. 810-815, 2013.
- [20] M. Firouzi, G.B. Gharehpetian, M. Pishvaei, A dual-functional bridge type FCL to restore PCC voltage, *International Journal of Electrical Power & Energy Systems*, Vol. 46, pp. 49-55, 2013.
- [21] Amir Heidary, Hamid Radmanesh, Seyed Hamid Fathi and Hamid Reza Rajabi Khamse, "Improving Transient Recovery voltage of circuit breaker using Fault Current Limiter", *Research Journal of Applied Sciences, Engineering and Technology* vo.4, no.23, pp.5123-5128, 2012.
- [22] C.S. Chang, P.C. Loh, Integration of fault current limiters on power systems for voltage quality improvement, *Electric Power Systems Research*, vol. 57, Issue 2, 5 pp. 83-92, 2001