

Voltage Control Approach in Smart Distribution Network with Renewable Distributed Generation

S. Jadid¹

O. Homae²

A. Zakariazadeh³

1 Center of Excellence for Power System Automation and Operation, Dept. of Electrical Engineering, Iran University of Science and Technology, Tehran, Iran

jadid@iust.ac.ir

2 Center of Excellence for Power System Automation and Operation, Dept. of Electrical Engineering, Iran University of Science and Technology, Tehran, Iran

homae@elec.iust.ac.ir

3 Center of Excellence for Power System Automation and Operation, Dept. of Electrical Engineering, Iran University of Science and Technology, Tehran, Iran

zakaria@iust.ac.ir

Abstract :

Voltage control is one of the imperative issues in the smart distribution control system. While traditional distribution network is equipped with communication and monitoring equipment, the online voltage control can be perfectly achieved. With using these smart grid technologies, the distribution voltage control schemes should carry out intelligently and cover the undesirable effect of high penetration of renewable distributed generation. This paper presents a new approach that improved the conventional voltage control models. The proposed approach needs measuring and communication equipment less than other methods, and can cover the renewable distributed generation impact on distribution network. The proposed online voltage control model was tested on typical distribution network. The results show that the proposed model can stabilize voltage in predefined range in different consumer load fluctuation conditions and variable renewable generation levels.

Keywords: Voltage control, Capacitor, Renewable distributed generation, Remote Terminal Unit (RTU), Smart grid.

Submission date: 19 Nov. 2012

Conditional acceptance date: 19 May 2013

Acceptance date: 23 Jul. 2013

Corresponding author: Shahram Jadid

Corresponding author's address: Electrical Eng. Dep., Iran University of Science and Technology, University Road,

Hengam Ave., Resalat Square, Tehran, Iran.



1. Introduction

Utilizing Distributed Energy Resources (DER) in distribution system lead to increase reliability and reduce emission. Because of global warming, most of governments have planned to develop distributed generations (DG) implementation [1]. However, control and operation of many DGs may have some challenges for Distribution System Operator (DSO). In general, the Smart grid concept is a key to achieve all advantages like high level of reliability and low level of emission. With complete implementation of smart grid, most of DGs control challenges will be solved. In smart power system, the monitoring and control aspects of system operation process will be properly performed. Communication infrastructure through the power system makes possible monitoring and control of all equipment like all DGs. One of the important aspects of DG effects is related to voltage control process. So the DSO should consider the effect of DGs on voltage profile. In other hand, the DSO must coordinately schedule and set all voltage control equipment such as capacitors and transformer tap changer.

In [2-5] the voltage control issue is solved by optimization algorithm for day ahead scheduling. Disadvantage of these methods is that they require forecasted daily load and power output forecasted of renewable distributed generation. In [6], the author focused on the tasks of substation transformers with Load Tap Changers (LTCs) on smart grids. Voltage and reactive power control are one of LTCs' tasks. A voltage control pattern in smart distribution grid was proposed in [7]. In [8] the authors propose the concept of a decentralized nonhierarchical voltage regulation architecture based on intelligent and cooperative smart entities. In [9], the authors presented a methodology that uses the potential of the smart grids applied to increase the voltage control efficiency in the distribution systems. In [10], the problem of voltage regulation has been well addressed by studying the impacts of DGs on the voltage profile and the operation of step voltage regulators (SVR) and feeder shunt capacitors. However, the IEEE P1547 Standard [11] specified that the DG units should not regulate distribution system voltages. An attempt by a DG unit to regulate distribution system voltage can conflict with existing voltage regulation schemes applied by the utility to regulate the same or a nearby point to a different voltage. Currently most of the installed DGs are commonly connected to operate at unity power factor to avoid interference with the voltage regulation devices connected to the system [12].

In [13], a new approach for voltage regulators function's improvement in multiple feeders which include DGs was proposed. This model is based on placing RTU, which communicate with each other in a certain order, at each DG unit and each capacitor bus.

With data which received from RTUs, the maximum and minimum voltage of feeders was estimated and, hence, it able to regulate the voltage of the feeder, or multiple feeders.

In this paper, an online voltage control model is proposed that has 2 advantages than previous works compromising of lower communication equipment as well as reduction of calculations that were carried out by RTUs. The propose model is design for smart distribution grid. This control can do by DSO as a centralized control or use by any substation or microgrid operator as decentralize control. With installing Advanced Metering Infrastructure (AMI), the required data for using the proposed model will simply be achieved. Thus the proposed online voltage control can be implemented in a distribution network which equip with AMI system.

This paper is organized as follows. Section II details the various impacts of DGs on distribution voltage profile. Section III specifies how the maximum and minimum voltage was estimated and describe proposed model. Section IV discusses the simulation case and results from those studies. Sections V and VI include discussion and conclusion.

2. Impacts of DGs on Distribution voltage Profile

Distributed generation units connection to distribution system will strongly affect on feeders flow and voltage profile. These effects will so remarkable because of small X/R ratio of distribution feeders. This aspect of DGs on distribution system was shown in Fig. 1. Voltage drop from bus 1 to bus 2 is calculated as (1) [13-14]:

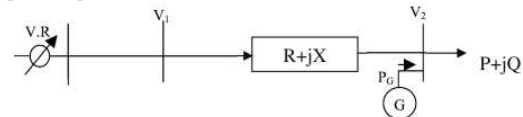

Fig. 1: Two bus test system

$$V_1 - V_2 = (R + jX) \times \left[\frac{(P - P_G) - jQ}{V_2^*} \right] \quad (1)$$

$$V_1 - V_2 = \frac{[R(P - P_G) + XQ] + j[X(P - P_G) - RQ]}{V_2^*}$$

Since the X/R ratio of distribution network is low, the imaginary part of voltage could be ignored. In per unit, the equation (1) can be written as follows:

$$V_1 - V_2 = R(P - P_G) + XQ \quad (2)$$

As the load consumptions and power output of DGs (especially photo voltaic units) alter during a 24 hours period, the voltage drop will be changed through this period.

3. Online Voltage Control Pattern

While the power injection of one or multiple DGs or the power consumption of customers change, the voltage in some buses may exit the permissible range. For regulating by voltage regulator, the maximum and minimum voltage estimation through the feeders will be required.

In a typical distribution system, the maximum voltage could occur in DG buses, capacitor buses or substation bus. However, the point with lowest voltage may be placed in the end buses or between DG buses [13]. Minimum voltage points can usually take place only at the end of the feeder as well as in between any DG connecting buses. The voltage of the end points can be read by RTU.

For minimum voltage point estimation, it is assumed that the load between the two DG units is concentrated halfway between them. In Fig. 2, the value of the minimum voltage in a point between the DG₁ and DG₂, is calculated by DG₂ eq. (3) [13]:

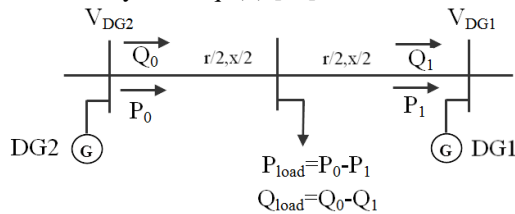

Fig. 2.: Part of a distribution system

$$V_{est,DG2,DG1} = V_{DG2} - (P_0 \frac{r}{2} + Q_0 \frac{x}{2}) \quad (3)$$

Also, the value of the minimum voltage in a point between two DGs calculated by DG₁ is given by:

$$V_{est,DG1,DG2} = V_{DG1} + (P_1 \frac{r}{2} + Q_1 \frac{x}{2}) \quad (4)$$

A better estimation is achieved by averaging these two values:

$$V_{est} = \frac{V_{est,DG1,DG2} + V_{est,DG2,DG1}}{2} \quad (5)$$

In this study, the amount of measuring data is given from offline backward/forward sweeping power flow which DG units were modeled as PQ bus and were considered as negative loads. This method addressed in [15-16].

3.1. Proposed System Structure

In this part, the structure of distribution network with installed RTUs, capacitors and DGs of proposed model are described.

3.1.1. SCADA and RTU System

SCADA solutions for Distribution Automation (DA) and Distribution Management Systems (DMS) deliver comprehensive benefits for monitoring and control tasks. Modern SCADA provides proper monitoring of equipment to maintain operations at an optimal level by identifying and correcting problems before they turn into significant system failures.

A SCADA system is made up of a number of remote terminal units (RTUs) collecting field data and sending that data back to a master station via a communications link. The RTU provides an interface to the field analog and digital sensors situated at each remote site. The master station displays the acquired data and also permits the operator to perform remote control tasks [17].

Fig. 3 is a block diagram presenting how the Energy Management System (EMS) software is linked to the capacitors and DGs in the modern distribution grid. Starting with the RTU, the measurement and internal calculations are carried out by each RTU, and the specified parameters are sent to another RTU. This procedure is continuing until the estimated maximum and minimum voltage data are delivered to the master SCADA. Finally, the controller set the voltage regulator based on estimated minimum and maximum voltage of feeders.

3.1.2. Proposed Distribution System's Configuration

The proposed system structure is shown in Fig. 4. In this system, one RTU was installed on each DG and capacitor's bus. The communication link between RTUs is also presented in Fig. 4. Each RTU should measure some local parameters, and perform a simple calculation. Fig. 5 depicts the parameter that the RTUs need to measure. Each RTU measures the voltage of its bus, active and reactive power flow in lines connected to its bus.

3.2. Proposed Algorithm

In the proposed algorithm, the maximum and minimum voltage is calculated by each RTU and the output result send to next RTU as an input data. For clarification, let RTU_n be the RTU connected to a specific capacitor bank and RTU_{n-1} to be the upstream RTU, the RTU connected to the DG upstream from the first DG. Also, define RTU_{n+1} to be the downstream RTU. The flowchart depicted in Fig. 6, shows the calculation process by RTU_n. Basically, the algorithm can be clarified as follows: the farthest DG or capacitor's RTU calculates the maximum and minimum voltage and send the data for its upstream RTU.

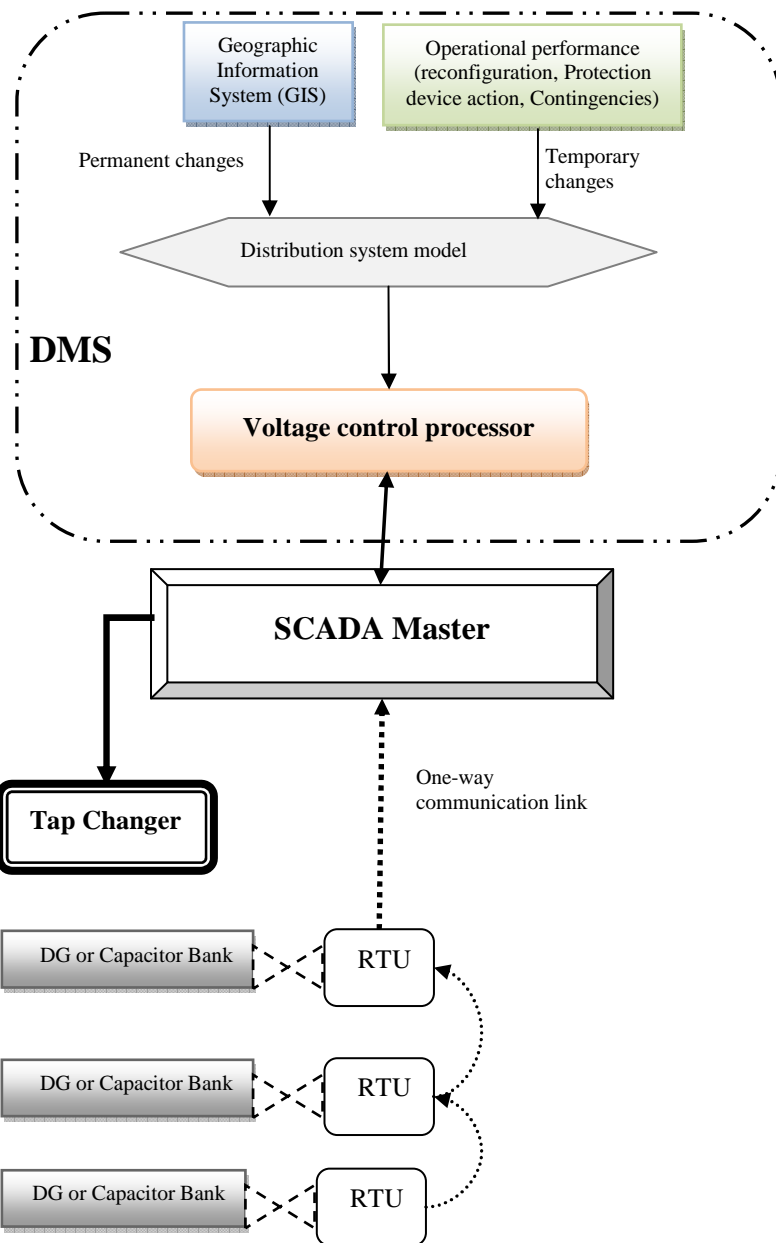

Fig. 3: DMS, SCADA and RTU configuration

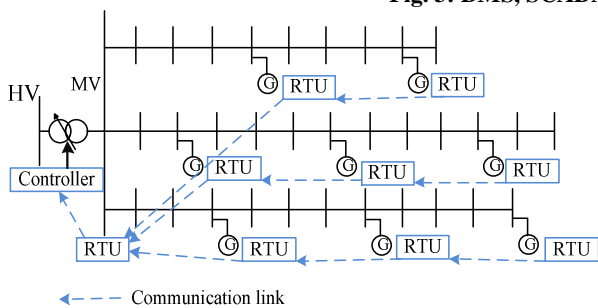

Fig. 4: Structure and position of equipments in proposed approach

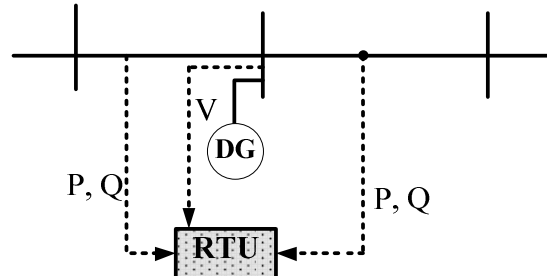

Fig. 5: Details of RTU measurements

Upon receiving these data from the downstream RTU, the upstream RTU will compute the maximum and minimum voltage based on input data from

downstream RTU and its measured parameters. This procedure continues while the estimated maximum and minimum voltage data is received by voltage control processor. For example, according to the flowchart, the RTU_n with its local measurements estimates the voltage profile between RTU_{n+1} and its node using the following equation:

$$V_{est,n,n+1} = V_n - \left(P_{n,n+1} \cdot \frac{r_{n,n+1}}{2} + Q_{n,n+1} \cdot \frac{x_{n,n+1}}{2} \right) \quad (6)$$

Now the average estimated voltage for the distance between RTU_n and RTU_{n+1} is calculated by means of the above estimated voltage and the similar estimated voltage by RTU_{n+1} for this distance. This equation is given by (7) [13]:

$$V_{est,n} = \frac{V_{est,n,n+1} + V_{est,n+1,n}}{2} \quad (7)$$

Then the maximum and minimum voltage is determined based on the RTU_n place voltage (i.e. V_n), estimated voltage $V_{est,n}$ and estimated maximum and minimum voltage for downstream feeders of RTU_n (i.e. $V_{max,n+1}, V_{min,n+1}$). In the next stage, the voltage in a point between RTU_n and RTU_{n-1} will be estimated with equation (8):

$$V_{est,n,n-1} = V_n - \left(P_{n,n-1} \cdot \frac{r_{n,n-1}}{2} + Q_{n,n-1} \cdot \frac{x_{n,n-1}}{2} \right) \quad (8)$$

Finally, the values of $V_{max,n}, V_{min,n}$ and $V_{est,n-1}$ is sent to upstream RTU.

As some of calculations are carried out by each RTU, the transferred data and the calculation time will reduce. Comparing with common SCADA, the proposed model shows faster reaction to voltage variation.

3.3. Voltage Regulator Controller

After in receipt of the maximum and minimum voltages of each feeder, the voltage regulator will determine the absolute maximum and minimum voltage of all the feeders. Based on these values, the voltage regulator will calculate the tap position changing accordingly as follows:

$$Tap = tap_0 + \text{round} \left[\frac{\left(1 + \frac{V_{max\ feeders} - V_{min\ feeders}}{2} \right) - V_{max\ feeders}}{T_{apr}} \right] \quad (9)$$

The basic condition that has to be satisfied in order the voltage regulator controller to find a suitable tap that will regulate the maximum and the minimum voltages of all feeders is:

$$V_{max\ feeders} - V_{min\ feeders} < \min \left[\begin{matrix} V_{max\ perm} \\ -V_{min\ perm} \end{matrix} \right], (\Delta V) \quad (10)$$

Where ΔV represents the maximum possible change in voltage level at secondary side of transformer, and is

calculated by multiplication of total tap steps in a tap voltage ratio. If situation (10) does not hold then one regulator cannot handle the voltage regulation of the entire system. In such situation there might be a need to install more voltage regulators in the system.

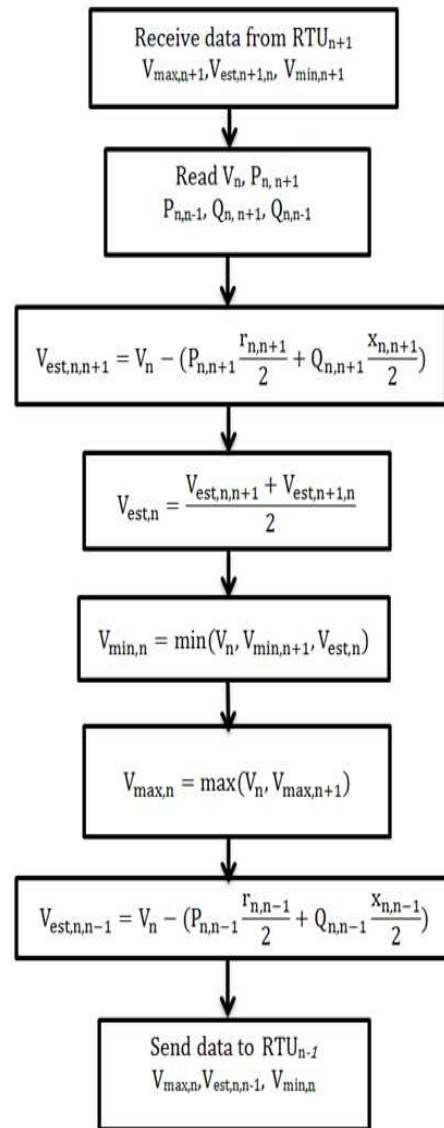

Fig. 6: Procedure of RTU_n.

4. Case Studies

In this section several simulation results will be reported to validate the proposed voltage regulation scheme. Fig. 7 shows a single-line diagram of a test distribution network. The load data is listed in Table 1. In this table, consumer type 1 is commercial and its load profile at 24 hours was shown in Fig. 8. Consumers' type 2 is residential which their load profile was depicted in Fig.9.

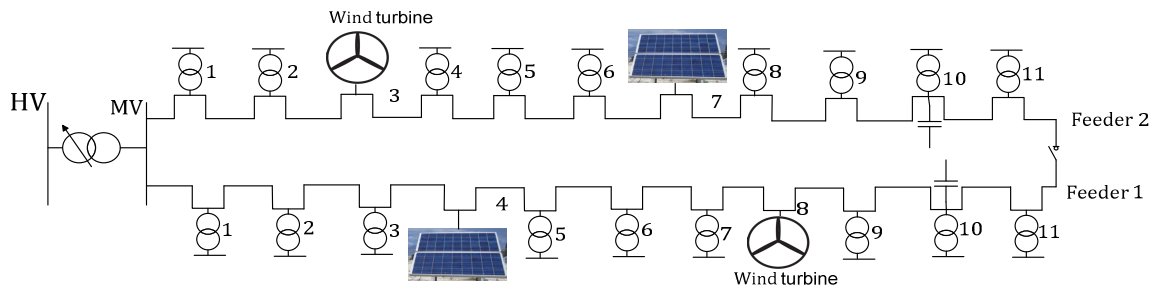

Fig. 7: System used for simulations

Table 1: Load data

Feeder 1				Feeder 2			
Bus number	Maximum active power (kW)	Type of customer	Power factor	Bus number	Maximum active power (kW)	Type of customer	Power factor
1	130	1	0.8	1	150	2	0.85
2	200	2	0.85	2	200	1	0.8
3	275	2	0.85	3	-	-	-
4	-	-	-	4	350	1	0.8
5	300	2	0.85	5	400	2	0.85
6	375	1	0.8	6	275	2	0.85
7	225	2	0.85	7	-	-	-
8	-	-	-	8	175	2	0.85
9	225	1	0.8	9	175	2	0.85
10	350	1	0.8	10	300	2	0.85
11	375	2	0.85	11	250	1	0.8

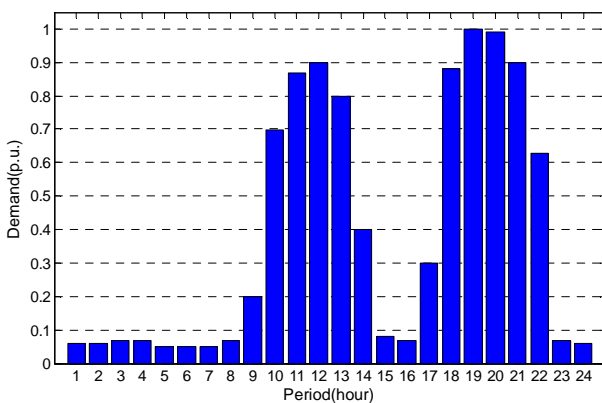

Fig. 8: Consumer type 1

Four DGs are connected to buses 4 and 8 on the first feeder and buses 3 and 7 on the second feeder. These DGs are selected renewable distributed generation type, to consider the renewable generation effects on voltage regulation pattern. Two wind turbine units are connected to bus 8 on feeder 1 and bus 3 on feeder 2 that maximum output of these wind units are 700 kW

and 800 kW, respectively. The output generation per unit profile at 24 hours of these units was given in Fig. 10. Also two photovoltaic units are connected to bus 4 on feeder 1 and bus 7 on feeder 2 that maximum output of these photovoltaic units are 300 kW (Fig. 11).

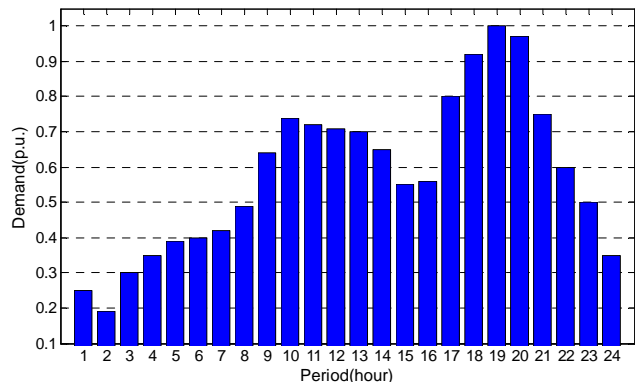

Fig. 9: Consumer type 2

The installed capacitors are at bus 10 of feeder 1 and bus 10 of feeder 2 which their capacities are 1200 kVAr. The number of taps in voltage regulator is 10 and each tap ratio is 0.01 pu. The impedance of each

line is considered $0.85+j0.8$ ohm. Also nominal voltage of this system is 11 kV. In the last buses of test system, a normally open breaker is installed that connects two feeders. In this study this breaker is normally considered open.

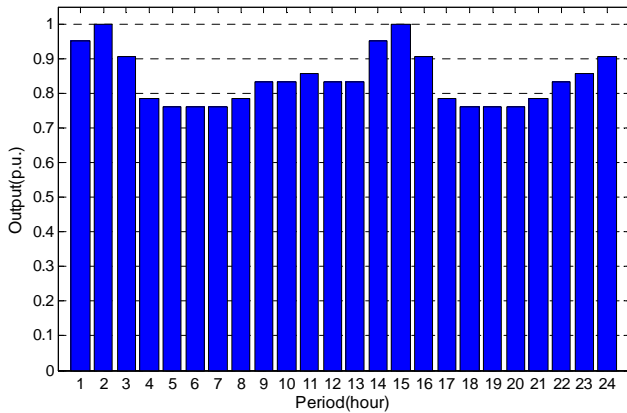

Fig. 10: Output of wind turbine

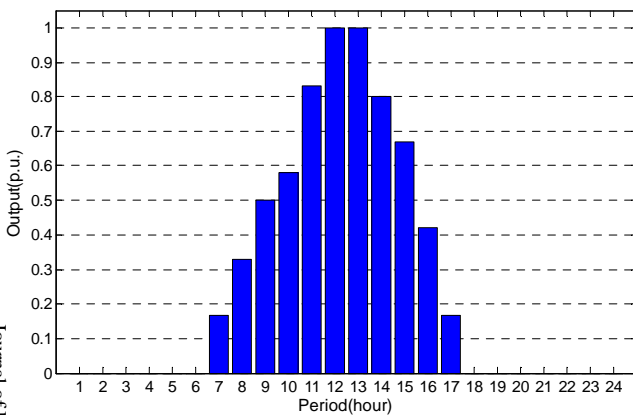

Fig. 11: Output of PV

Using the proposed voltage control algorithm, the tap situation of voltage regulator is set based on load fluctuations of consumers and alternation of wind and photovoltaic units output. The result over 24-hour period is presented in Fig. 12.

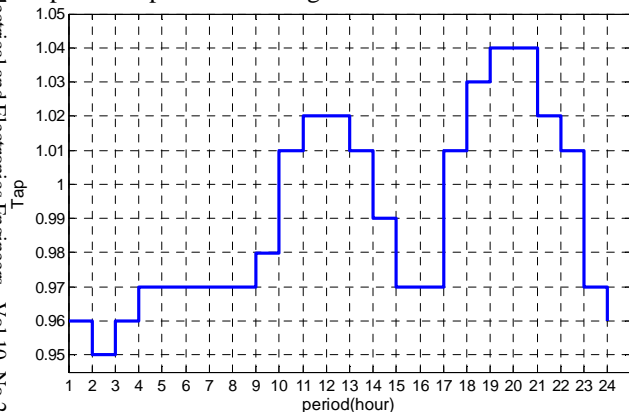

Fig. 12: Tap position based on proposed method

As seen from Fig. 12, the tap position decreased at hours when the load was low and the power production was high; because don't let the voltage exit from maximum permissible range. Also at high load consumption and low power production period, the tap situation increased to not let the voltage exit from minimum permissible range. If the whole required data from network like real time load consumption and DGs output power are available, the maximum and minimum voltage of network will be calculated by power flow algorithm. The tap condition using power flow result was given in Fig. 13.

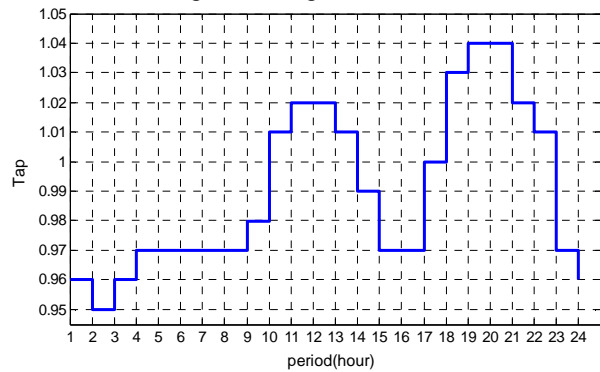

Fig. 13: Tap position based on load flow

The efficiency and validation of proposed VVC is approved by comparing the result of tap condition by real online data and estimated data from proposed algorithm. The results which depicted in Fig. 12 and Fig. 13 are so comparable. The voltage profile of all buses on feeder 1 before applying voltage regulation is drawn in Fig. 14. As seen from this Figure, the voltage in the end buses leave the upper limit on the hours 1-6 and drop below the lower limit on peak load. The voltage profile of this feeder after applying proposed voltage regulation method is shown in Fig. 15. The results show that the voltages on all buses in all hours bring back to their permissible range.

The voltage profile before and after voltage regulation at 19:00 was shown in Fig. 16. Since the power output of PV reduced and load consumption increased simultaneously at 19:00, voltage exited from permissible range on feeders 1 and 2. After voltage regulation with proposed approach, the voltage brings to predefined ranges. In Fig. 17, the voltage profile of feeders 1 and 2 on 2:00 before and after regulation is shown. In this hour, the demand is low and the renewable generation is high. So the voltages on some buses leave their upper limit. After voltage regulation, voltages on all buses bring back to their permissible range.

As a result, the proposed model can solve the voltage problems that the increase of renewable penetration in the distribution system are caused.

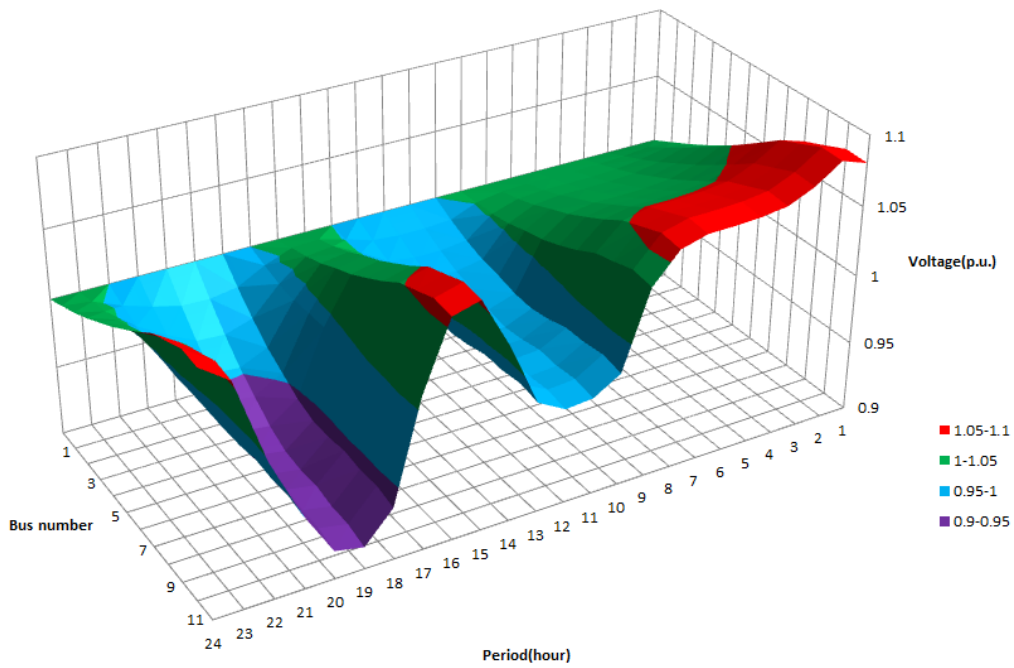

Fig. 14: Voltage profile of feeder 1 before regulation

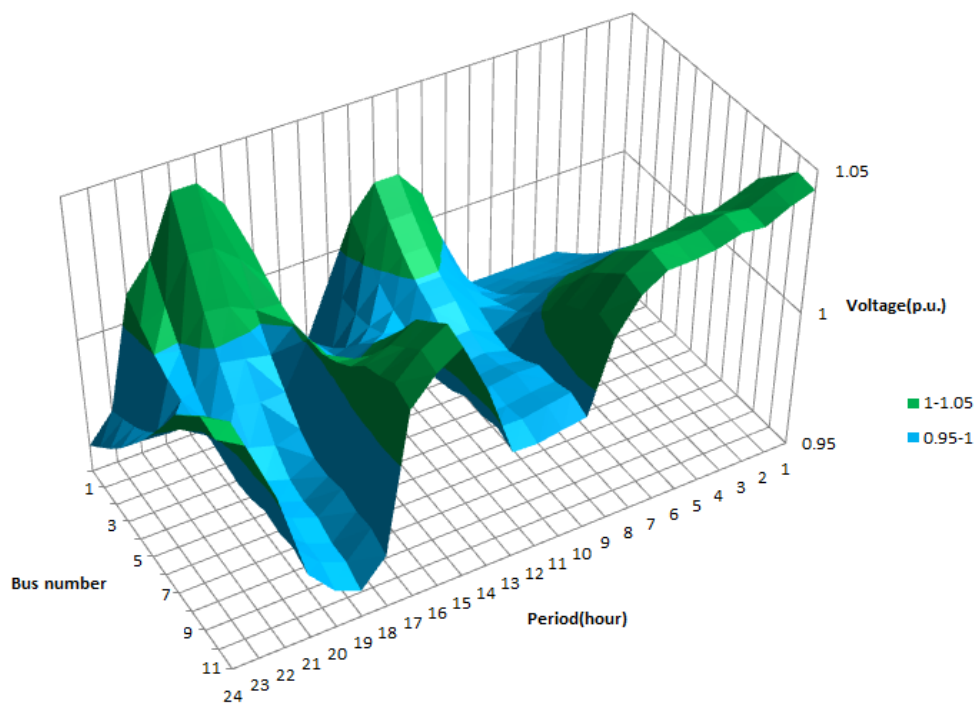

Fig. 15: Voltage profile of feeder 1 after regulation

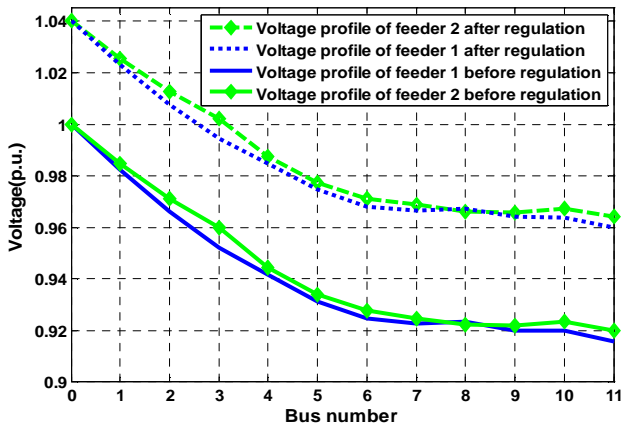

Fig. 16: Voltage profile before and after voltage regulation at 19:00

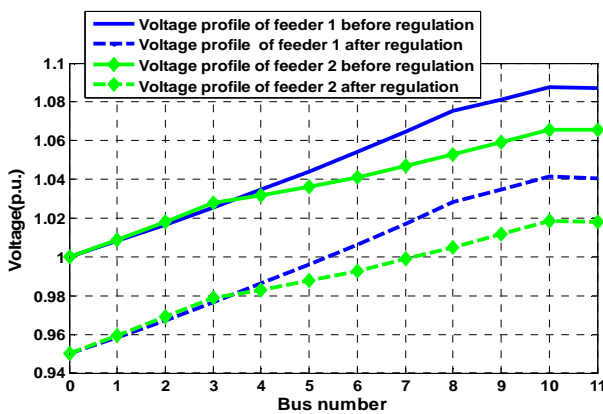

Fig. 17: Voltage profile before and after voltage regulation at 2:00

In Fig. 18 the voltage profile before and after regulation in bus 11 on feeder 1 was presented.

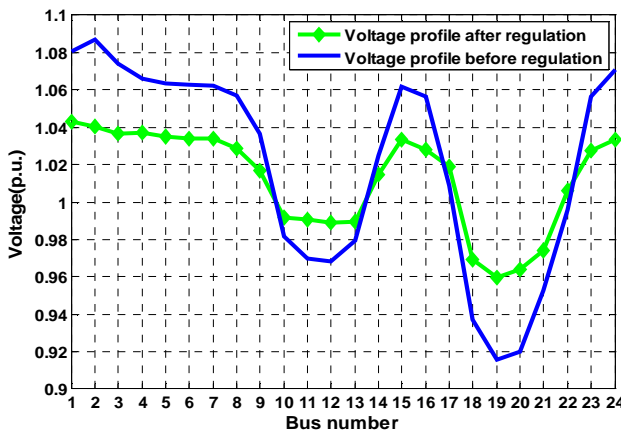

Fig. 18: Voltage profile before and after regulation in bus 11 on feeder 1

As seen from Fig. 18, the voltage drops at early night hours and exit from permissible ranges. Then by voltage regulating with proposed algorithm, the voltage brings to its permissible range.

In Fig. 19 the voltage profile before and after regulation in bus 11 on feeder 2 was presented.

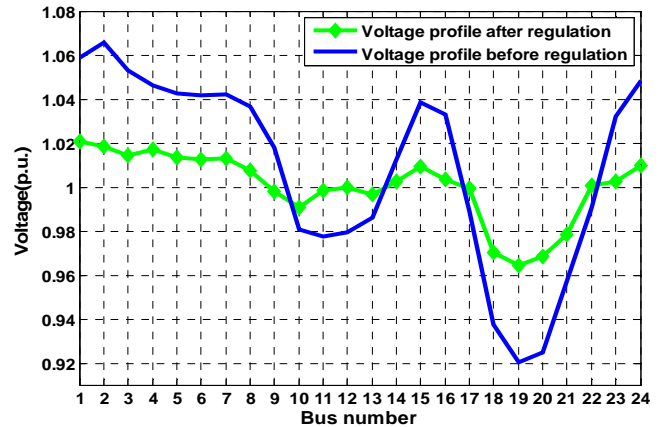

Fig. 19: Voltage profile before and after regulation in bus 11 on feeder 2

As seen from Fig. 19, the voltage drops at early night hours and exit from permissible ranges. Then by voltage regulating with proposed algorithm, the voltage brings to its permissible range.

5. Discussion

As mentioned before, if situation (10) does not hold, then one regulator cannot handle the voltage regulation of the entire system. In this situation there are two solutions. First, the operator can install more voltage regulators in the system. Installing extra voltage regulators in the system will provide more flexibility for voltage control. So, the maximum and minimum voltages of the original system will occur in two different control zones. In this case, RTU installed in each control zone will report to the voltage regulator responsible for that zone. Second option is using the other voltage control devices such as switched capacitors and load curtailments. While the proposed voltage control algorithm realizes that is not able to act in this situation, a signal is sent to main voltage controller processor. Then, voltage control system selects other available voltage control devices and algorithms to use in this situation. The main focus of this paper is on the tap changer action in voltage regulation using RTUs real time data. The other voltage control algorithms such as switched capacitors or load curtailment are defined as future works.

Time delay is one of the most important issues in every control and monitoring systems [18]. In the proposed model, the latency of tap changer actuation should be considered. To avoid tap changer actuation in transient voltage fluctuations, the tap changer must wait to receive at least two consecutive measured data from RTUs. As, the RTUs installed only on DGs or capacitors buses, the number of RTUs are acceptable [19]. Also, the RTUs data is received from each feeder, in parallel. So, the length of the longest feeder is the base of delay time calculation, not the whole distribution area. However, if the delay time is high,

there are some technical ways such as implementing faster communication infrastructures and parallel data exchange to reduce the delay time [20-21]. The maximum latency in receiving measured data from all RTUs in a feeder is calculated as sum of internal time calculation of each RTU and total data transfer time between RTUs installed on a feeder.

6. Conclusion

A coordinated online voltage control method is proposed in this paper to reach capable voltage regulation for multiple feeders in the presence of renewable distribution generation. The technique is based on locating RTU at each DG bus. Each RTU communicate with its neighbors. In this voltage control algorithm, the maximum and minimum voltage of feeders is calculated by RTUs. The controller of tap changer sets the voltage based on receiving data from RTUs. The proposed scheme needs lower measured parameters which leads to reduction of communication and measurement equipment in comparing of previous work. The RTU calculation process was also reduced in this pattern. The simulation results show the proposed voltage control algorithm is efficient and could be used in smart distribution system operation.

Appendix

Nomenclatures

$V_{\max,n+1}$	The value of feeder's maximum voltage received from downstream RTU _{n+1}
$V_{\min,n+1}$	The value of feeder's minimum voltage received from downstream RTU _{n+1}
$V_{\text{est},n,n+1}$	The estimation of voltage between RTU _n and RTU _{n+1} calculated by RTU _n .
$V_{\text{est},n+1,n}$	The estimation of voltage between RTU _n and RTU _{n+1} calculated by RTU _{n+1} .
V_n	The voltage of the DG and capacitor bus at which RTU _n is connected.
$P_{n,n+1}$	The active power flow from RTU _n bus to RTU _{n+1} bus.
$Q_{n,n+1}$	The reactive power flow from RTU _n bus to RTU _{n+1} bus.
$V_{\max,\text{feeders}}$	The absolute maximum voltage of all the feeders.
$V_{\min,\text{feeders}}$	The absolute minimum voltage of all the feeders.
$V_{\min,\text{perm}}$	The permissible minimum voltage of

the system.

$V_{\max,\text{perm}}$	The permissible maximum voltage of the system.
$r_{n,n+1}$	The lines resistance between RTU _n and RTU _{n+1} .
$x_{n,n+1}$	The lines reactance between RTU _n and RTU _{n+1} .
tap ₀	The tap position of voltage regulator in before stage.
Tap _r	The step of voltage regulator.
Tap	The optimum tap position of voltage regulator.

References

- [1] A. Hesami, F. Habibi, H. bevrani, "Robust control design for stabilizing of microgrid voltage in different operating conditions", Journal of Iranian Association of Electrical and Electronics Engineers, Vol. 10, No.1, pp. 23-32, 2013.
- [2] T. Niknam, "A new HBMO algorithm for multiobjective daily Volt/Var control in distribution systems considering Distributed Generators", Applied Energy 88, pp. 778-788, 2011.
- [3] A. R. Malekpour, T. Niknam "A probabilistic multi-objective daily Volt/Var control at distribution networks including renewable energy sources", Energy 36, pp.3477-3488, 2011.
- [4] R. H. Liang, Y. K. Chen, Y. T. Chen, "Volt/Var control in a distribution system by a fuzzy optimization approach" Electrical Power and Energy Systems 33, pp.278-287, 2011.
- [5] T. Niknama, B. Bahmani Firouzi, A. Ostadi, "A new fuzzy adaptive particle swarm optimization for daily Volt/Var control in distribution networks considering distributed generators", Applied Energy 87, pp.1919-1928, 2010.
- [6] E. T. Jauch, "Possible Effects of Smart Grid Functions on LTC Transformers ", IEEE transactions on industry applications, vol. 47, no. 2, march 2011.
- [7] E. Tom Jauch, "Implementing "SMART GRID" Integrated Distribution Volt/var/kW Management," IEEE, Transmission and Distribution Conference and Exposition, April. 2010.
- [8] A. Vaccaro, G. Velotto, A. F. Zobaa," A Decentralized and Cooperative Architecture for Optimal Voltage Regulation in Smart Grids," IEEE Trans. Industrial electronics, Vol. 58, No. 10, 2011.
- [9] P. Pereira, L. Canha , R. Milbradt, A. Abaide, S. Schmaedecke, G. Arend, E. Madruga " Optimization of Voltage Regulators Settings and Transformer Tap Zones in Distribution Systems with Great Load Variation Using Distribution Automation and the Smart Grids Initiatives ", 8 International Conference on the European Energy Market, May 2011.
- [10] H.E. Farag, E. F. El-Saadany, "Voltage Regulation in Distribution Feeders with High DG Penetration: From Traditional to Smart", IEEE, Power and Energy Society General Meeting, July 2011.

- [11] IEEE Standard for Distributed Resources Interconnected With Electric Power Systems, IEEE P1547 Std, Sep. 2002.
- [12] R. S. Al Abri, E. F. El-Saadany, Y. M. Atwa, "Optimal Placement and Sizing Method to Improve the Voltage Stability Margin in a Distribution System Using Distributed Generation", IEEE Transactions On Power Systems, Vol.28, No. 1, pp.326-334, 2013.
- [13] M. E. Elkhatib, R. El-Shatshat, M. M. A. Salama " Novel Coordinated Voltage Control for Smart Distribution Networks With DG", IEEE transactions on smart grid, vol. 2, no. 4, December 2011.
- [14] T. Niknam, "A new approach based on ant colony optimization for daily Volt/Var control in distribution networks considering distributed generators ", Energy Conversion and Management 49, pp.3417-3424, 2008.
- [15] L. A. Gallego, E. Carreno, A. Padilha-Feltrin, " Distributed Generation Modeling for Unbalanced Three-phase power Flow Calculations in Smart Grids ", IEEE/PES Transmission and Distribution Conference and Exposition, Latin America, 2010.
- [16] H. E. Farag, E.F. El-Saadany, R.El Shatshat, A.Zidan "A generalized power flow analysis for distribution systems with high penetration of distributed generation", Electric Power Systems Research 81, pp.1499-1506, 2011.
- [17] M. M. Ahmed, and W. L. Soo, "Customized (SCADA) System for Low Voltage Distribution Automation System", Transmission & Distribution Conference & Exposition: Asia and Pacific, Oct 26-30, 2009, pp. 1-4, Seoul, Korea.
- [18] J.I. Escudero, J. Luque, I. Gomez, A. Menendez, "Real delay measurement in distributed systems," IEEE Trans. On power delivery, 13(3), 1998, pp. 807-813.
- [19] Remote Terminal Unit RTU560, System description release 6.2, ABB Utilities GmbH, 2004.
- [20] F. Gunnarsson, F. Gustafsson, "Time delay compensation in power controlled cellular radio systems," IEEE Communications Letters, 5(7), Jul. 2001, pp. 295-297.
- [21] Connecting to the IESO: Setting up Your Remote Terminal Unit (RTU) and Dispatch Workstation (DWS) Marketplace Training Revised: March 2012 online available at: www.ieso.ca/imoweb/pubs/training/connectRTU_DWS.pdf