

# Analysis and Synthesis of Facial Expressions by Feature-Points Tracking and Deformable Model

H. Seyedarabi<sup>1</sup>, A. Aghagolzadeh<sup>1</sup>, S. Khanmohammadi<sup>1</sup>, E. Kabir<sup>2</sup>

1- Faculty of Electrical and Computer Eng.,

University of Tabriz, Tabriz, Iran

[seyedarabi@tahoo.com](mailto:seyedarabi@tahoo.com), [aghagol@tabrizu.ac.ir](mailto:aghagol@tabrizu.ac.ir), [khan@tabrizu.ac.ir](mailto:khan@tabrizu.ac.ir)

2- Department of Electrical Eng.,

Tarbiat Modarres University, Tehran, Iran

## Abstract:

Face expression recognition is useful for designing new interactive devices offering the possibility of new ways for human to interact with computer systems. In this paper we develop a facial expressions analysis and synthesis system. The analysis part of the system is based on the facial features extracted from facial feature points (FFP) in frontal image sequences. Selected facial feature points were automatically tracked using an improved cross-correlation based motion tracking algorithm, and extracted feature vectors from the position of FFPs in the first and the last frames, were used to classify expressions and Action Units (AU), using Probabilistic Neural Networks (PNN). Comparing with similar analysis works, we improved analysis system recognition rate by using improved motion tracking system and some new facial features. The synthesis part of the system uses a deformable patch object model that models facial features (eyes, eyebrows and mouth) by small polygons. The coordinates of the vertices of these polygons can be changed based on the FFP positions in the original image. The synthesis part of the system can be used as an on-line personalized facial animator by tracking some FFPs in the original image, or as a generic facial expressions animator by applying some parameters for each AU code (off-line animation). The proposed deformable model has a simple structure and uses a few set of control points comparing to the similar face models.

**Keywords:** Facial feature points, Probabilistic Neural Network, Deformable face model, Facial animation.

## 1. Introduction

Face plays an essential role in interpersonal communication. Automating facial expression analysis could bring facial expressions into man-machine interaction.

In 1971 Ekman and Friesen [1] postulated six primary emotions that each possess a distinctive content together with a unique facial expression. These prototypic emotional displays are also referred to as basic emotions. They seem to be universal across human ethnicities and cultures and comprise happiness, sadness, fear, disgust, surprise, and anger.

In recent years, there has been extensive research on face recognition, facial expression recognition and facial animation. Black and Yacoob [2] used local parameterized models of image motion for facial expression analysis. Non-rigid motions of facial features within the local facial areas of eyebrows, eyes, and mouth, were represented by affine-plus-curvature model. The initial regions for the head and the facial features were selected by hand and thereafter automatically tracked.

Kobayashi [3, 4] applied a  $234 \times 50 \times 6$  neural network for classification of expression into one of the six basic emotion categories. The units of the input layer correspond to the number of the brightness distribution data extracted from an input facial image, while the units of the output layer correspond to one emotion category. The neural network has been trained by 90 images of the six basic facial expressions shown by 15 subjects and it has been tested on a set of 90 facial expressions images shown by another 15 subjects. The average recognition rate was 85 percent.



Cohn et al. [5] developed an optical-flow based approach that is sensitive to subtle changes in facial expression. In image sequences from 100 young adults, action units and action unit combinations in the brow and mouth regions were selected for analysis if they occurred a minimum of 25 times in the database. Selected facial features were automatically tracked using a hierarchical algorithm for estimating optical flow. Image sequences were randomly divided into training and test sets.

Erol [6] described a facial modeling and animation system that used muscle-based generic face model and deformed it using deformation techniques to model the individualized faces. Two orthogonal photos of the real faces, frontal and side images, were used for this purpose. Image processing techniques were employed to extract certain features on the photographs, which were then refined manually by the user through the facilities of the user interface of the system. The feature points located on the frontal and side views of a real face were used to deform the generic model. Then, the muscle vectors in the individualized face model were arranged accordingly. The individualized face models produced in this manner were animated using the parametric interpolation techniques.

In this paper we develop a facial expressions analysis and synthesis model with capability of analyzing the facial expressions into one of the six basic emotions or a set of AUs and synthesizing the same expressions on an animated face model. The analysis part of the system is based on the facial features extracted from FFPs in the frontal image sequences. Selected FFPs are automatically tracked and the extracted feature vectors are used to classify expressions using PNN classifier. Comparing with related works [2-5] we improved analysis system performance by using some new features and improving motion tracking method and using PNN classifier. The synthesis part of the system uses an animated face model that models facial features by small deformable polygons. The proposed deformable model has a simple structure and uses a few set of control points comparing to the similar face models [6].

In section 2, we describe the analysis system structure, FFP tracking algorithm, feature extraction and PNN classifier structure. Experimental results for classifying basic emotions and action units are also given in this section. The proposed face model is described in section 3. In this section on-line and off-line facial animation structures are described and the proposed face model is evaluated. Conclusions and future works are given also in section 4.

## 2. Analysis system structure

The proposed facial animation model can be used directly for tracking facial expressions from input facial image sequences. On the other hand, the proposed model has the capability of analyzing facial expressions into one of the six basic emotions or a set of AUs. The analysis part of the system is based on the facial features extracted from movement of the FFPs in frontal image sequences. Selected FFPs were automatically tracked using a cross-

correlation based motion tracking algorithm, and extracted feature vectors were used to classify expressions and AUs. At first, we classify the input image sequences into one of the six basic emotions using PNN classifiers. Then some of these expressions are decomposed into the AUs. Fig. 1 shows analysis system structure.

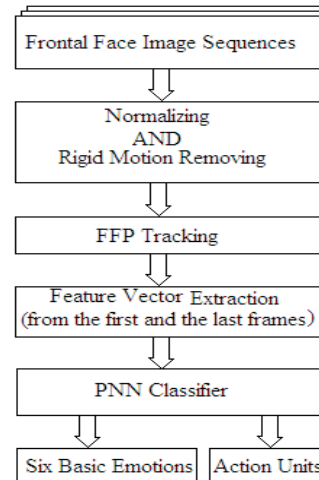

Fig. 1: Analysis system structure

### 2.1. Facial Feature Point Tracking

In this paper we used an improved cross-correlation based motion tracking method by adding some constraints on estimating the direction of pixel movements. Some FFPs have movement only in one direction and we can restrict search window in the next frame (vertically or horizontally). This assumption results in a reliable motion estimation by improving direction estimation and reducing complexity.

For further complexity reduction, 14 key FFPs were manually marked around facial features such as eyes, eyebrows and mouth (Fig. 2) in the first frame and motion estimation is restricted only to tracking these points. The Facial Action Coding System (FACS) is a human-observer-based system designed to detect subtle changes in facial features. Among 44 AUs in the FACS, 39 AUs are directly associated with the movement of eyes, eyebrows and mouth [1]. That is why the information expressing these movements is desirable for machine recognition of facial expressions. We are confined in these three components and determine the facial feature points which are representative of the boundary of these components.



Fig. 2: Selected 14 FFPs.

Each point was considered as the center of a  $11 \times 11$  flow window that includes horizontal and vertical flows. Cross-correlation of  $11 \times 11$  window in the first frame with a  $21 \times 21$  window at the next frame were calculated and the position by maximum cross-correlation value for two windows, were estimated as the position of the feature point for the next frame. Fig. 3 shows the implementation of this method in two subsequent frames.

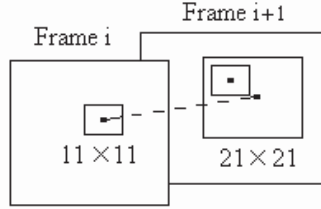

Fig. 3: Cross-correlation based motion tracking

To calculate a reliable motion tracking, it has been assumed that after removing rigid motions of the head, points 2, 5, 6, 11 and 12 in Fig.2 have only vertical movement in the subsequent frames. This assumption reduces the search window size in the next frame from  $21 \times 21$  to  $21 \times 5$ . Also window size for point 10 increases from  $11 \times 11$  to  $15 \times 15$ , for improving its position estimation because of its gray level ambiguity that may occur in the search window.

We extracted some features from normalized position of the FFPs in the first and the last frames (peak facial expression frame). These features are used to analyze facial expressions into one of the six primary emotions or into a set of single or composite AUs.

## 2.2. Feature Extraction from Feature Points

Seven features were extracted from normalized position of the FFPs in the first and the last frames. These features form the feature vector for each expression. Extracted features are as follows:

Width of eye:

$$f1 = (x_3 - x_4) \quad (1)$$

Height of eyebrows 1:

$$f2 = (y_9 - y_2) \quad (2)$$

Height of eyebrows 2:

$$f3 = (y_9 - y_1) \quad (3)$$

Width of mouth:

$$f4 = x_{14} - x_{13} \quad (4)$$

Openness of mouth:

$$f5 = y_{12} - y_{11} \quad (5)$$

Nose tip-lip corners distance:

$$f6 = \frac{(y_{13} - y_9) + (y_{14} - y_9)}{2} \quad (6)$$

Eye- cheek distance:

$$f7 = (y_{10} - y_7) \quad (7)$$

The ratio of these features in the first and the last frames forms a  $7 \times 1$  feature vector for each expression.  $(x_i, y_i)$  represents the coordinate of FFPs which the origin of X-Y coordinate system is assigned to the tip of nose. Inner eye corners distance (IED) was used for normalizing the extracted features to remove the effect of object distance from the camera.

$$IED = \sqrt{(x_3 - x_8)^2 + (y_3 - y_8)^2} \quad (8)$$

Also the angle of the line joining these corners was used for removing the head rigid motions [8-11]:

$$\theta = \tan^{-1} \left( \frac{y_3 - y_8}{x_3 - x_8} \right) \quad (9)$$

Comparing with the related works that used similar features [3, 4], we get higher recognition rate by adding some new features (f3, f6 and f7) and improving motion tracking method.

## 2.3. Probabilistic Neural Network (PNN) Classifier

Neural networks have been employed and compared to conventional classifiers for a number of classification problems. The results have shown that the accuracy of the neural network approaches is equivalent to, or slightly better than the other methods. PNN is a variant of the Radial Basis Function Neural Networks (RBFNN) and attempts have been carried out to make the learning process in this type of classification faster than normally required for the multi-layer feed forward neural networks. The construction of PNN involves an input layer, a hidden layer and an output layer with feed forward architecture. The input layer of this network is a set of R units, which accept the elements of an R-dimensional input feature vector. The input units are fully connected to the hidden layer with Q hidden units (RBF units). Q is the number of input/target training pairs. Each target vector has K elements. One of these elements is 1 and the rest are 0. Thus, each input vector is associated with one of K classes.

RBF units use the Gaussian radial basis function as the activation function that is defined by:

$$RBF(c_i) = \exp(-(\|c_i - p\| b)^2) \quad (10)$$

$c_i$  is the center of the  $i$ th RBF unit,  $p$  is the input feature vector,  $b$  is the bias and  $\| \cdot \|$  denotes the Euclidean norm. RBF unit with a center quite different from the input vector  $p$  has an output near zero. This small output has only a negligible effect on the output neurons. In contrast, a RBF unit with a center close to the input vector  $p$  produces a value near 1. If a neuron has an output of 1 its output weights pass their values to the output neurons. Each bias in the RBF units is set to:



$$b = \frac{0.8326}{\sigma} \quad (11)$$

Which  $\sigma$  is the width of the Gaussian function. This gives the radial basis functions that cross 0.5 if distance of the input vector and the center of radial basis function equals  $\pm\sigma$ . This determines the width of an area in the input space to which each neuron responds.  $\sigma$  must be large enough so that the active input regions of the RBF units overlap enough so that several RBF units always have fairly large outputs at any given moment. This makes the network function smoother and results in better generalization for new input vectors occurring between input vectors used in the design. However  $\sigma$  should not be so large that each neuron is effectively responding in the same, large, area of the input space. The moral of the story is, choose  $\sigma$  large than the distance between adjacent input vectors, so as to get good generalization, but smaller than the distance across the whole input space.

The hidden layer centers matrix  $\mathbf{C}$  is set to the transpose of the matrix formed from the  $Q$  training pairs  $P^T$ . The output layer weights are set to the matrix  $\mathbf{T}$  of target vectors. Each vector has only a 1 in the row associated with that particular class of input, and 0 elsewhere.

When an input vector is presented in the input layer, the hidden layer computes distances from the input vector to the training input vectors, and produces a vector whose elements indicate how close the input is to a training input. The output layer sums these contributions for each class of inputs to produce its net output as a vector of probabilities. Finally, a compete transfer function on the output of the output layer picks up the maximum of these probabilities, and produces a 1 for that class and 0 for the other classes [8-11].

## 2.4. Image Database

In this work, we used Cohn-Kanade database [7] that consists of expression sequences of subjects, starting from a neutral expression and ending with the peak of the facial expression. There are 104 subjects in the Cohn-Kanade database. Subjects sat directly in front of the camera and performed a series of the facial expressions that included the six primary emotions and also some single Action Unit (AU), (e.g. AU25) and some combinations of AUs (e.g. AU6+12+25). Since not all of the single and composite AUs sequences are exist in the database, we used a subset of subjects (50 subjects). For each person there are on average of 12 frames for each expression (after eliminating alternate frames). Image sequences for the frontal views are digitized into  $640 \times 490$  pixel array with 8 bits grayscale. Table 1 shows Cohn-Kanade database specifications.

**Table 1: Some specifications of the Cohn-Kanade Database**

Age	18 to 50
Female	69%
Male	31%
Euro-American	81%
Afro-American	13%
Other groups	6%
Resolution	640×490 Grayscale
Frame rate	30 fps

## 2.5. Experimental Results: Classifying into the six basic emotions

We used the sequence of 40 subjects as training sequences, and the sequence of the remaining 10 subjects as test sequences. This test is repeated five times, each time leaving different subjects out. The number of the input layer units in the PNN classifier is equal to 7, the number of extracted features, the number of the hidden layer units equals to  $40 \times 6$ , the number of training pairs and that of the output layers is 6, which corresponds to six kinds of facial expressions. For this problem  $\sigma$  is set to 0.9. Table 2 shows the recognition rate of the test for this classifier. Comparing these results with similar works [2-5] shows the reasonable recognition results.







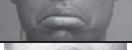





**Table 2: PNN classifier test results**

Recognition (%)	Happiness	Surprise	Sadness	Anger	Disgust	Fear
Happiness	<b>100</b>	0	0	0	0	0
Surprise	1.4	<b>96.2</b>	0	0	0	2.4
Sadness	0.9	0	<b>87.1</b>	6	6	0
Anger	0	0	9	<b>89.6</b>	1.4	0
Disgust	0.9	0	3.4	0	<b>95.7</b>	0
Fear	0	12	6.8	0	0	<b>81.2</b>

## 2.6. AUs classifier

Most of the current works on the facial expression recognition, attempt to recognize a small set of prototypic expressions. However the most of the human emotions are communicated by changes in one or two of discrete features. Since not all of the single and composite Action Units sequences were available in the databases, we used a subset of subjects for which the selected single and composite AUs were available. The results of feature extraction from an image sequence of facial expression are represented by a  $7 \times 1$  feature vector (the same features that described in the section 2.2). We want to classify each sequence into one of the predetermined AU in the single AU images and combinations of AUs in the composite AU images. Table 3 shows Facial Action Coding System (FACS) AUs used in this work that occur in the upper part and lower part of the face.

**Table 3: Some of FACS AUs used in this work [1]**

AU	NAME	
1	Inner brow raise	
2	Outer brow raise	
4	Brow corrugators	
5	Upper lid raise	
6	Cheek raise	
12	Lip corner pull	
15	Lip corner depress	
17	Chin raise	
23	Lip tighten	
24	Lip press	
25	Lips part	
26	Jaw drop	
27	Mouth stretch	

Those AUs which are important to the communication of the emotion and occurred at least 25 times in our data base, were selected for analysis. This frequency criterion ensures sufficient data for training and testing. Therefore 35 subjects were selected for the single AU and 53 subjects for the composite AUs classification. We used the image sequence of some subjects as test sequences (7 subjects for the single AU and 10 subjects for the composite AUs classifier), and the image sequence of the remaining subjects as training sequences. This test was repeated five times, each time leaving different subjects out. Training target vector for a single AU images was a  $3 \times 1$  vector which contained one for the existing AU and zeros for the others. For composite AU images, training target vector was a  $12 \times 1$  vector which contained ones for the existing AUs and zeros for the others. Manual FACS codes that were available for our database were used to form these vectors. We used the proposed PNN classifier as a decision making mechanisms [11]. Selected single AUs are shown in Fig. 4.

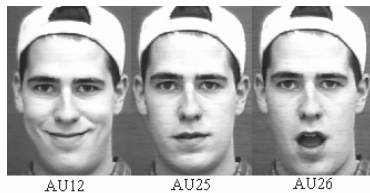

**Fig. 4: Selected single AUs.**

Single AUs recognition results from the proposed PNN classifier are shown in Table 4.

**Table 4: Single AUs recognition results**

Recognition	AU12	AU25	AU26
AU 12	83%	17%	0%
AU 25	0%	84%	16%
AU 26	0%	11%	89%

Selected composite AUs are shown in Fig. 5.



**Fig. 5: Selected composite AUs.**

Composite AUs recognition results for the proposed PNN classifier are shown in Table 5.

### 3. Synthesis System and Face Model

The synthesis part of the system can be used as either a personalized or a generalized facial animation. In the personalized animation case, model parameters such as mouth width, eye width and face landmarks are directly determined from first frame of the input image sequences and FFPs tracking results are directly applied to the model and the same expressions are synthesized. In the generalized facial animation case, a general face model that is an animated character is considered. The stored position of the FFPs from the analysis procedure for one of the subjects in database, that were showing the same facial expression, is applied to synthesize the input facial expression or AU codes in the face model. Fig. 6 shows the structure of the personalized and the generalized facial animation systems.



**Table 5: Composite AUs recognition results**

Recognition Rate (%)	AU 1	AU 2	AU 4	AU 5	AU 6	AU 12	AU 15	AU 17	AU 23	AU 24	AU 25	AU 27
AU1	<b>98</b>	2	0	0	0	0	0	0	0	0	0	0
AU2	2	<b>98</b>	0	0	0	0	0	0	0	0	0	0
AU4	12	15	<b>73</b>	0	0	0	0	0	0	0	0	0
AU5	0	0	0	<b>98</b>	2	0	0	0	0	0	0	0
AU6	0	0	0	9	<b>91</b>	0	0	0	0	0	0	0
AU12	0	0	0	0	0	<b>91</b>	7	2	0	0	0	0
AU15	0	0	0	0	0	8	<b>88</b>	4	0	0	0	0
AU17	0	0	0	0	0	7	2	<b>91</b>	0	0	0	0
AU23	0	0	0	0	0	0	0	0	<b>73</b>	27	0	0
AU24	0	0	0	0	0	0	0	0	27	<b>73</b>	0	0
AU25	0	0	0	0	0	0	0	0	0	0	<b>91</b>	9
AU27	0	0	0	0	0	0	0	0	0	0	2	<b>98</b>

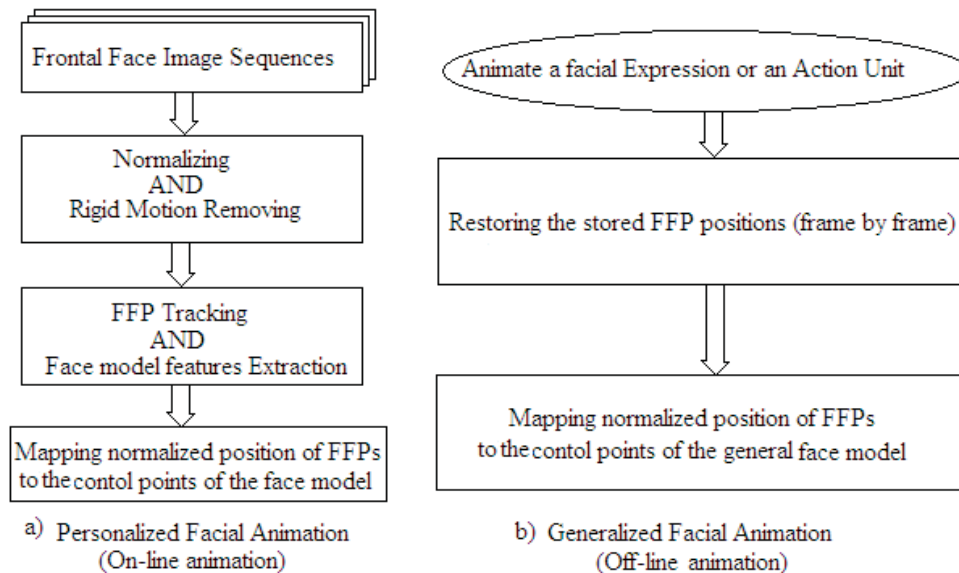

**Fig. 6: a) personalized facial animation systems b) generalized facial animation systems**

For designing the personalized facial animation model some feature points were added to those showed in Fig. 2. In the case of the generalized face model, we do not need to determine these extra points. Fig. 7 shows these feature points. Supposing symmetry for the model, only the RHS points were used. Some of these points were used only for specifying the model features in the first frame. Other points were automatically tracked in the subsequent frames using cross-correlation based motion tracking. In the subsequent sections we describe the specifications of the proposed face model.

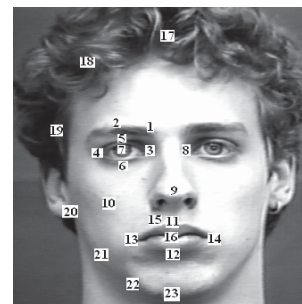

**Fig. 7: Selected 23 facial feature points.**

### 3.1. Facial Animation Model

We are confined in three facial features: mouth, eyes and eyebrows. We used a deformable model that uses small polygons to represents the features of the model. The vertices of these polygons were determined from the feature points tracking results. Deformable polygons gave the ability of shape tracking for the model. In the following subsections we describe the mouth, eyes and eyebrows models.

#### 3.1.1 Mouth Model

Fig. 8 shows the selected mouth feature points and the model features that were extracted from these points.

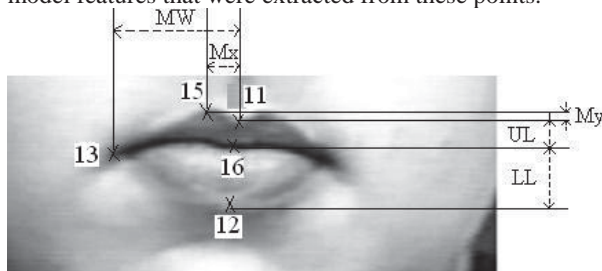

Fig. 8: Mouth features and feature points

Points 11, 12 and 13 were tracked in the subsequent frames and their position were transferred to the mouth model. But the other points were only used in the first frame for determining some features such as mouth width, upper and lower lip thickness.

Fig. 9 shows the proposed mouth model. The coordinates of the vertices 1, 8 and 15 were directly determined from the normalized position of the 11, 12 and 13 feature points in the Fig. 8 (UL were normalized to one). Coordinates of the other vertices were determined from the features MW, Mx, My, UL and LL relative to 1, 8 and 15 vertices. Right hand side of the model is the symmetry of the left hand side. Comparing this model with Erol's lip model [6], the number of vertices in our model is about one-half of that model leading to a reasonable deformability.

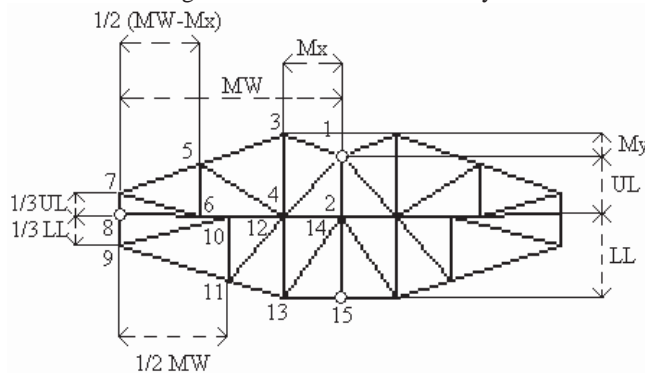

Fig. 9: Mouth model

#### 3.1.2. Eye and Eyebrow Model

Fig. 10 shows the selected eye and eyebrow feature points and the model features that were extracted from these points.

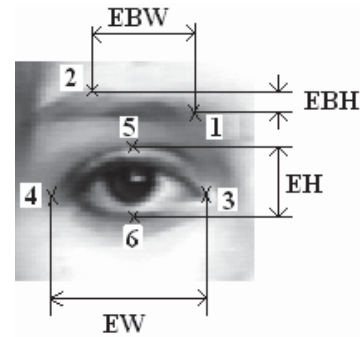

Fig. 10: Eye and Eyebrow features and feature points

Points 1, 2, 5 and 6 were tracked in the subsequent frames and the other points were only used in the first frame for determining features such as width and height of the eye and eyebrow.

Fig. 11 shows the proposed eye and eyebrow model. The coordinates of the vertices 16, 17, 30 and 31 were directly determined from normalized position of the 5, 6, 1 and 2 feature points in Fig. 10. Coordinates of the other vertices were determined from features EH, EW, EBH and EBW relative to 16, 17, 30 and 31 vertices. For example width of the iris assumed to be one-half of the EW. Right hand side of the model is the symmetry of the left hand side.

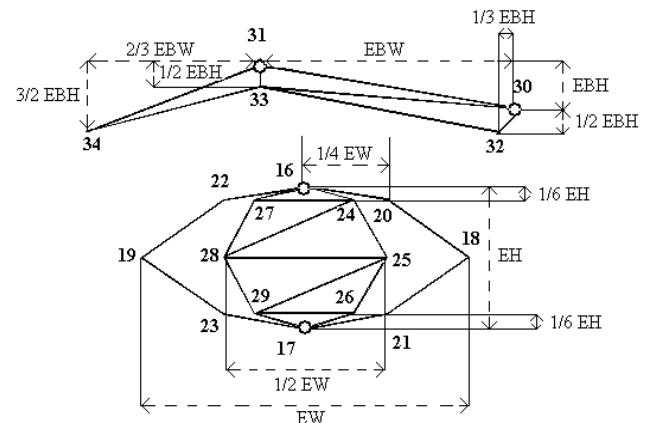

Fig. 11: Eye and Eyebrow model

Face landmarks were determined by using 7 landmark points around the face in the first frame (points 17-23 in the Fig. 7). These points were not tracked in subsequent frames, but the displacement of the points around the jaw (points 21-23 in the Fig. 7) was synchronized with the movement of the point 12.

Synthesis system can be used as an on-line personalized facial animator by tracking the defined FFPs in the original image, or as a generic facial expressions animator by applying some parameters for each AU code. For each frame, these parameters were determined from the analysis of facial expressions and FFP positions for the subjects of the database. For example parameters for generating AU26 (determining position of vertices in Fig. 9) in 12 frames over the generalized face model were determined from motion tracking results of points 11, 12 and 13 in Fig. 8 for



one of the subjects in the database that showed the AU26. These parameters (position of vertices) were stored for each frame and then were applied off-line to the general animated face model to show the same action unit for that frame.

### 3.2. Experimental Results: Deformation of the Face Model

The proposed face model was evaluated with the Cohn-Kanade database. Fig. 12 and Fig. 13 show some results of the on-line and the off-line animation. Fig. 12 shows the feature points tracking in the original face and the model deformation to show the same expressions. Tracked feature points in the original frames were also denoted in this figure. Fig. 13 shows the frames that are formed to show the animation for AU26.

The proposed model also can be used for lip tracking and speech synchronizing facial animation system. Fig. 14 shows the results of lip tracking for pronouncing the word "Salam", that means "Hello" in Persian [12].

### 4. Conclusion

In this paper we developed a facial expressions analysis and synthesis system. The analysis part of the system is based on the facial features extracted from facial characteristic points in the frontal image sequences. Selected facial feature points were automatically tracked using an improved cross-correlation based motion tracking, and the extracted feature vectors were used to classify expressions and Action Units, using PNN classifier. Using improved motion tracking system with adaptive search window and some new defined features, showed reasonable recognition rates. Synthesis system uses deformable model that models facial features by small polygons. The coordinates of the vertices of these polygons can be changed based on the FFP positions in the original face image. The proposed deformable model has a simple structure and uses a few set of control points comparing to the similar face models.

Since the majority of facial expressions have symmetry on the face, we used a symmetrical face model. Using unsymmetrical face model needs some extra FFPs and only affects model's complexity. Because of using the frontal images, we used a 2-D face model. By using the side images beside the frontal images and applying 3-D coordinates to the vertices of the model, 3-D face model can be obtained.

### Acknowledgement

The authors appreciate the support of Iranian Telecommunication Research Center (ITRC) for this research and would like to thank J.F. Cohn and T. Kanade from Pittsburgh University for their kindly providing the image database.

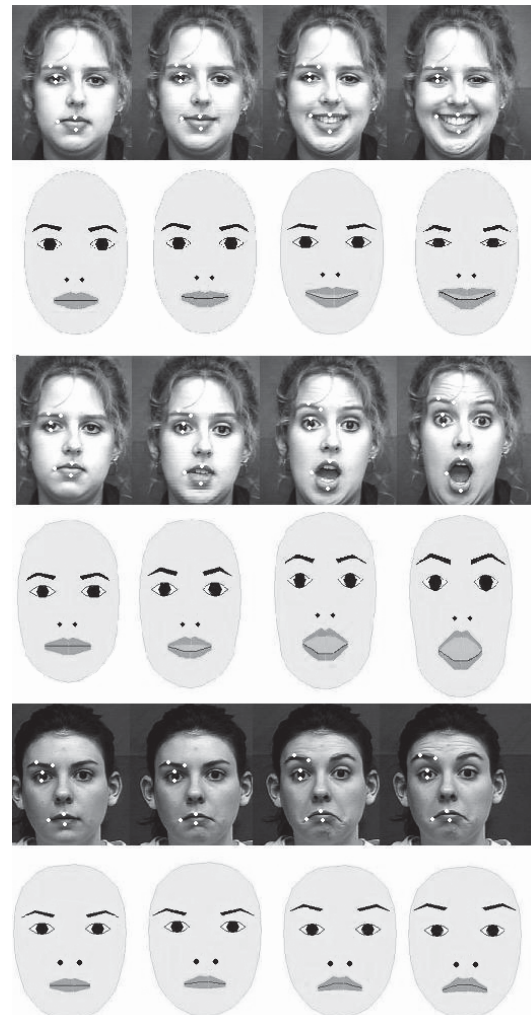

Fig. 12: On-line Facial expressions tracking and animating

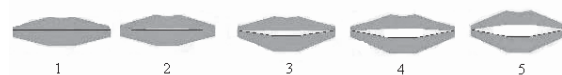

Fig. 13: Off-line animating for AU26

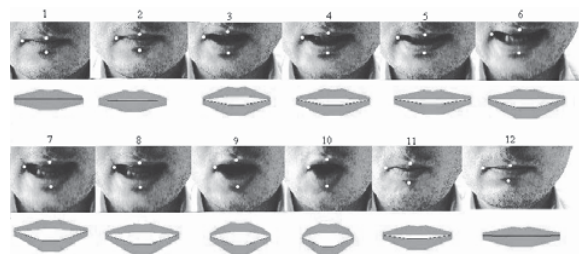

Fig. 14: Lip tracking for pronouncing the word "Salam"



## References

- [1] Ekman, P.; Friesen, W.V.: Facial Action Coding System (FACS): Consulting Psychologists Press, Inc., 1978.
- [2] Black, M. J.; Yacoob, Y.: Recognizing Facial Expression in Image Sequences using Local Parameterized Models of Image Motion. *Int. J. Computer Vision*, Vol. 25, no.1 (1997), 23-48.
- [3] Kobayashi, H.: Study on Face Robot Platform as a KANSEI Medium. *Int. J. Robotics and Mechatronics*, vol. 13, no. 5 (2001) 497-504.
- [4] Kobayashi, H.; Hara, F.: Recognition of Six Basic Facial Expressions and Their Strength by Neural Network. *Int. conf. ROMAN' 92*, Hachioji, Japan 1992, 381-386.
- [5] Cohn, J. F.; Zlochow, A.J.; Lien, J. J.; Kanade, T.: Feature-Point Tracking by Optical Flow Discriminates subtle Difference in Facial Expression. *Proc. IEEE Int. Conf. Automatic Face and Gesture Recognition*, Nara, Japan 1998, 396-401.
- [6] Errol, F.: Modeling and Animating Personalized Faces. M.Sc. Thesis, bilkent University, Turkey January 2002.
- [7] Kanade, T.; Cohn, J.; Tian, Y.: Comprehensive database for facial expression analysis, 2000.
- [8] Khanmohammadi, S.; Aghagolzadeh, A.; Seyedarabi, H.: Facial Expression Recognition from Static Images using RBF Neural Networks and Fuzzy Logic. *The 2<sup>nd</sup> Iranian conf. on Machine Vision and Image Processing (MVIP 2003)*, Tehran, 2003, 9-15 (in Farsi).
- [9] Seyedarabi, H.; Aghagolzadeh, A.; Khanmohammadi, S.: Facial Expressions Recognition from Image Sequences using Cross-correlation Based Optical-Flow and Radial Basis Neural Networks. *The 12<sup>th</sup> Iranian Conf. on Electrical Engineering, (ICEE 2004)*, Mashhad, 2004, 165-170 (in Farsi).
- [10] Seyedarabi, H.; Aghagolzadeh, A.; Khanmohammadi, S.: Recognition of Six Basic Facial Expressions by Feature-Points Tracking using RBF Neural Networks and Fuzzy Inference System. *IEEE Int. Conf. Multimedia & Expo (ICME2004)*, Taipei, Taiwan 2004.
- [11] Aghagolzadeh, A.; Seyedarabi, H.; Khanmohammadi, S.: Single and Composite Action Units Classification in Facial Expressions by Feature-Points Tracking and RBF Neural Networks. *Ukrainian Int. conf. signal/Image processing, UkrObraz 2004*, Kiev, Ukraine 2004, 181-184.
- [12] Seyedarabi, H.; Aghagolzadeh, A.; Khanmohammadi, S.: Facial Expressions Animation and Lip Tracking Using Facial Characteristic Points and Deformable Model. *Int. Conf. Computational Intelligence (ICCI 2004)*, Istanbul, Turkey 2004, 416-419.

